

TL24

series

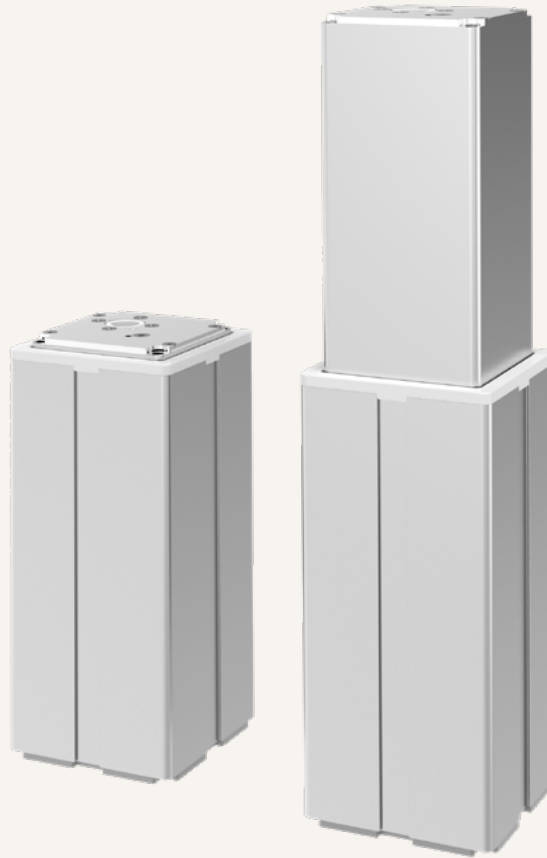

Product Segments

• Care Motion

TL24 electric lifting column is designed for medical applications such as height adjustable workstations, screens and optical machines. TL24 provides multiple cable exit options, such as from top end socket or top/bottom sides; besides, TL24 also support "direct cut system" which can be operated without control box, connecting the main power and hand control directly. The TL24 features an extruded aluminum rectangular 2 stage appearance.

General Features

Maximum load	3300N in push
Maximum dynamic bending moment	200Nm
Maximum static bending moment	400Nm
Maximum speed at full load	22mm/s (with 800N in a push condition)
Minimum installation dimension	≥ Stroke + 188mm
Stroke	100~800mm
Two stage outer tube with rectangular appearance	

Drawing

Standard Dimensions
(mm)

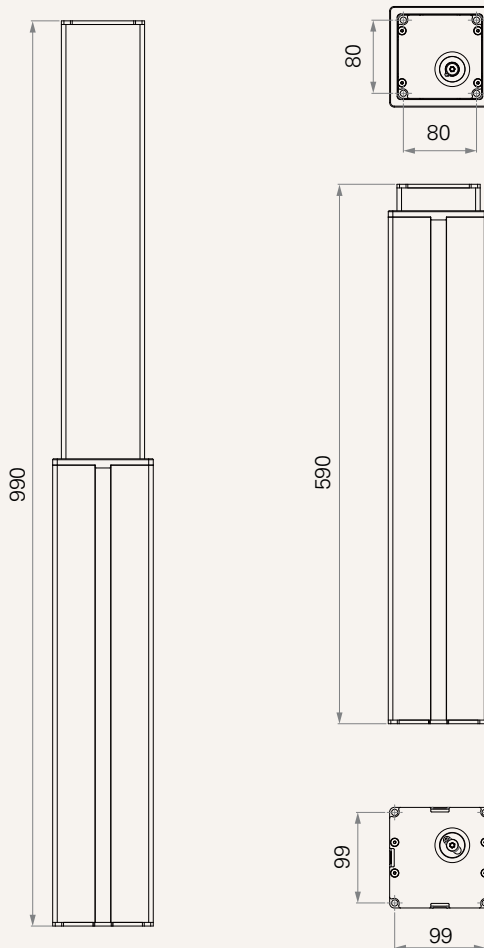

Load and Speed

CODE	Load (N)		Self Locking Force (N)	Typical Current (A)		Typical Speed (mm/s)	
	Push	Pull		No Load 32V DC	With Load 24V DC	No Load 32V DC	With Load 24V DC
Motor Speed (5600RPM, duty cycle 10%)							
G	3300	3300	1800	2.0	4.7	12.0	6.5
J	800	1800	800	2.0	3.2	17.0	10.5
L	800	800	300	2.5	5.0	38.0	22.0

Note

- Parameters above are from tested average, please refer to approval drawing for final value.
- This self-locking force level is reached only when a short circuit is applied on the terminals of the motor. All the TiMOTION control boxes have this feature built-in.
- The current & speed in table are tested with 24V DC motor. With a 12V DC motor, the current is approximately twice the current measured in 24V DC; speed will be similar for both voltages.
- Dynamic bending moment (Nm)- X direction:

Retracted Length (mm)	S+188	
100-400	200	
Stroke (mm)	401-600	200
601-800	200	

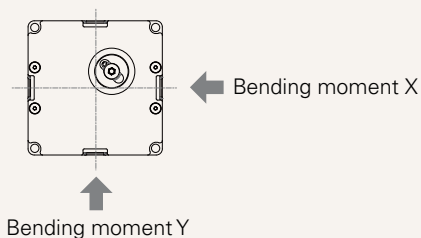

Performance Data (24V DC Motor)

Motor Speed (5600RPM, Duty Cycle 10%)

Speed vs. Load

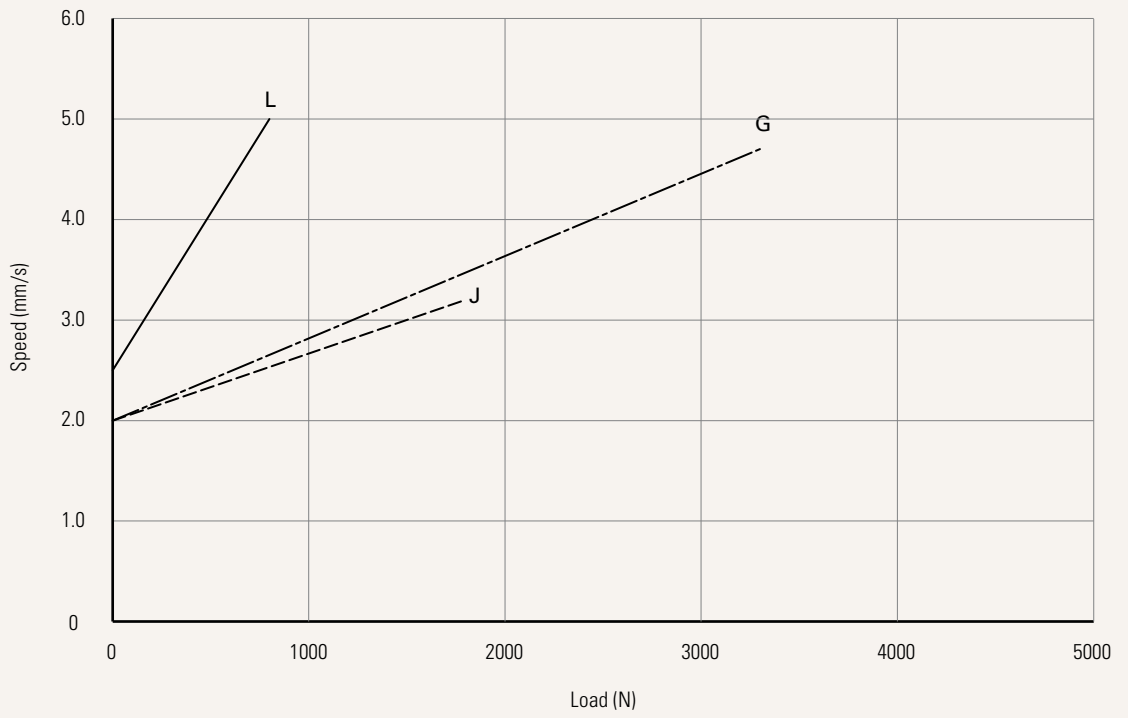

Current vs. Load

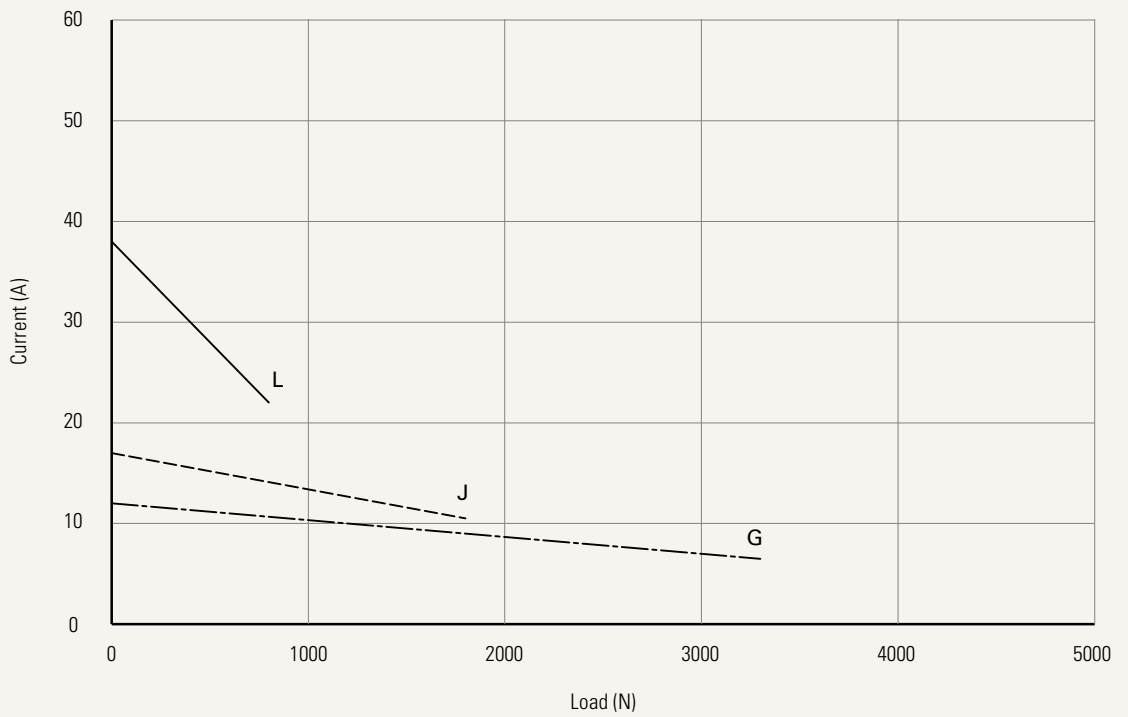

TL24 Top End Socket Ordering Key

TL24

Version: 20181114-D

Voltage	1 = 12V DC	2 = 24V DC	
Load and Speed	See page 2		
Stroke (mm)	100-800		
Retracted Length (mm)	See page 7		
Cable Exit See page 8	1 = Top end socket		
Special Functions for Spindle Sub-Assembly	0 = Without (Standard)	1 = Safety nut	
Functions for Limit Switches See page 8	1 = Two switches at full retracted / extended positions to cut current 3 = Two switches at full retracted / extended positions to send signal		
IP Rating	1 = Without	2 = IPX4	3 = IPX6
Output Signals	0 = Without	2 = Hall sensor*2	3 = POT
Connector See page 9	1 = DIN 6P, socket		
Cable Length (mm)	5 = Without (the corresponding extension cable TEC needs to be ordered seperately)		
Color	2 = Matte silver (With 428C color cable set)		3 = Matte silver (With black cable set)
Tubes Direction See page 10	0 = Thinner on top	1 = Wider on top	
Top Plate See page 10	1 = Small plate		
Bottom Plate See page 10	1 = Small plate		
Grounding Function	0 = Without		

Note

1 The TL24 is designed especially for push applications, not suitable for pull applications.

TL24 Side Cable Ordering Key

TL24

Version: 20181114-D

Voltage	1 = 12V DC	2 = 24V DC		
Load and Speed	See page 2			
Stroke (mm)	100-800			
Retracted Length (mm)	See page 7			
Cable Exit See page 8	2 = Bottom side cable		3 = Top side cable	
Special Functions for Spindle Sub-Assembly	0 = Without (Standard)		1 = Safety nut	
Functions for Limit Switches See page 8	1 = Two switches at full retracted / extended positions to cut current			
	3 = Two switches at full retracted / extended positions to send signal			
IP Rating	1 = Without	2 = IPX4	3 = IPX6	
Output Signals	0 = Without	2 = Hall sensor*2	3 = POT	
Connector See page 9	1 = DIN 6P, 90° plug	2 = Tinned leads	F = DIN 6P, 180° plug	
Cable Length (mm)	1 = Straight, 500	3 = Straight, 1000	5 = Straight, 1500	7 = Straight, 2000
	2 = Straight, 750	4 = Straight, 1250	6 = Straight, 1750	
Color	2 = Matte silver (With 428C color cable set)		3 = Matte silver (With black cable set)	
Tubes Direction See page 10	0 = Thinner on top		1 = Wider on top	
Top Plate See page 10	1 = Small plate			
Bottom Plate See page 10	1 = Small plate			
Grounding Function	0 = Without			

Note

1 The TL24 is designed especially for push applications, not suitable for pull applications.

TL24 Direct Cut Ordering Key

TL24

Version: 20181114-D

Voltage	1 = 12V DC	2 = 24V DC
Load and Speed	See page 2	
Stroke (mm)	100 - 800	
Retracted Length (mm)	See page 7	
Cable Exit See page 8	B = Top side- for TH; Bottom side- for TP C = Bottom side- Y cable, for TH + TP D = Top side- for the 2nd column; Bottom side- for TH & TP; direct cut operation with 2 columns E = Top side- for the 2nd column & TH; Bottom side- for TP; direct cut operation with 2 columns	
Special Functions for Spindle Sub-Assembly	0 = Without (Standard)	1 = Safety nut
Functions for Limit Switches See page 8	1 = Two switches at full retracted / extended positions to cut current	
IP Rating	1 = Without	2 = IPX4 3 = IPX6
Output Signals	0 = Without	
Connector See page 9	C = Direct cut, water proof, anti-pull	
Cable Length (mm) See page 9	B = Cable exit #B, L2=L3=100 C = Cable exit #C, L1=L2=L3=100	D = Cable exit #D, L2=L3=L4=10 E = Cable exit #E, L2=L3=L4=10
Color	2 = Matte silver (With 428C color cable set)	3 = Matte silver (With black cable set)
Tubes Direction See page 10	0 = Thinner on top	1 = Wider on top
Top Plate See page 10	1 = Small plate	
Bottom Plate See page 10	1 = Small plate	
Grounding Function	0 = Without	

Note

1 The TL24 is designed especially for push applications, not suitable for pull applications.

Retracted Length (mm)

1. Minimum retracted length needs to $\geq A+B+C$

A. Retracted Length (mm)	Load (N)		
	800	1800	3300
A	S+188		

B. Cable Exit	When with POT (When without POT, C=0)		
	Top End Socket	Bottom Side Cable	Top Side Cable
#	1	2	3
C	+36	+36	+36

B. Cable Exit	CODE	Top End Socket	Bottom Side Cable	Top Side Cable	Direct Cut	
					B, D, E	C
#		1	2	3	B, D, E	C
B		-	-	+15	+35	-

Cable Exit

1 = Top end socket

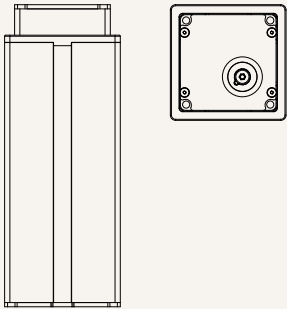

2 = Bottom side cable

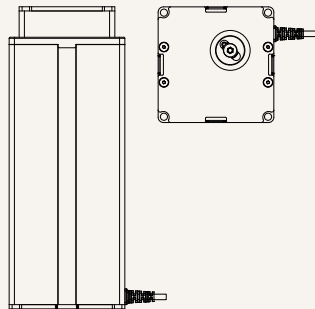

3 = Top side cable

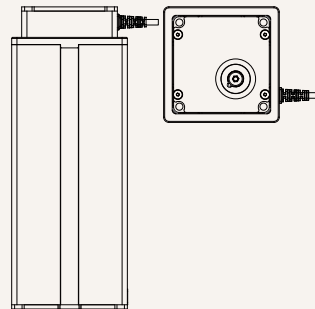

B = Cable exit #B, L2=L3=100

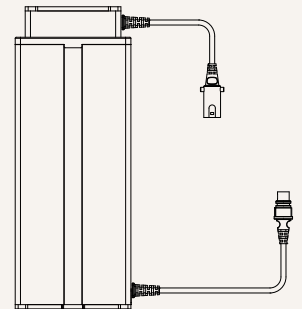

C = Cable exit #C, L1=L2=L3=100

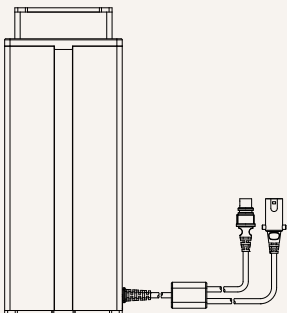

D = Cable exit #D, L2=L3=L4=10

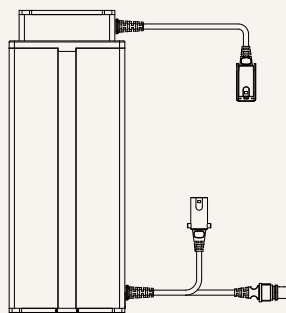

E = Cable exit #E, L2=L3=L4=10

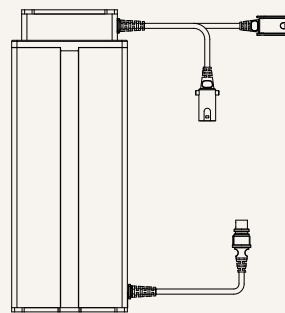

Functions for Limit Switches

Wire Definitions

CODE	Pin					
	1 (Green)	2 (Red)	3 (White)	4 (Black)	5 (Yellow)	6 (Blue)
1	extend (VDC+)	N/A	N/A	N/A	retract (VDC+)	N/A
3	extend (VDC+)	common	upper limit switch	N/A	retract (VDC+)	lower limit switch

Connector

1 = DIN 6P, socket (Top end socket)

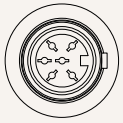

1 = DIN 6P, 90° plug (Side cable)

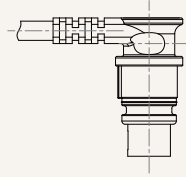

2 = Tinned leads

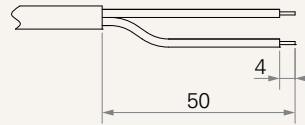

F = DIN 6P, 180° plug

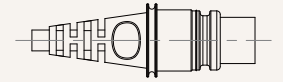

C = Direct cut, water proof, anti-pull

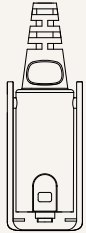

For TH:
long DIN 5P (Pin array 240°),
180° socket (with anti-pull clip)



For TP:
long DIN 5P (Pin array 240°),
180° plug (with O-ring)

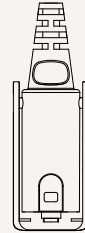

For Column 2:
long DIN 6P (Pin array 240°),
180° plug (with anti-pull clip)

Cable Length (mm)

B = Cable exit #B, L2 = L3 = 100

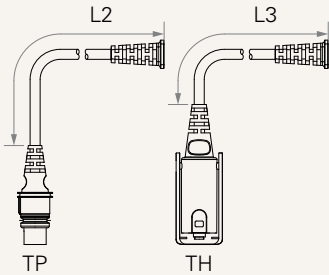

C = Cable exit #C, L1 = L2 = L3 = 100

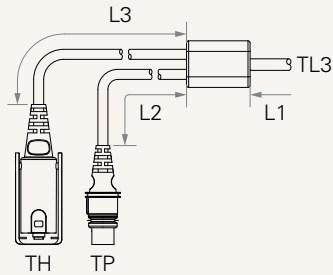

D, E = Cable exit #D, #E, L2 = L3 = L4 = 100

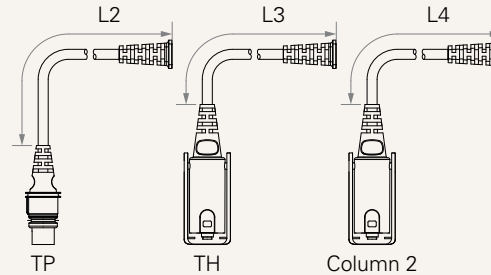

Top Plate

1 = Small plate

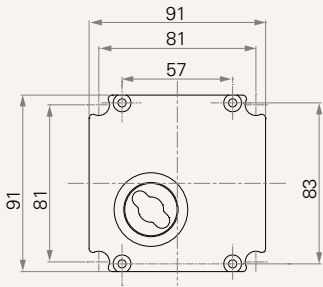

Bottom Plate

1 = Small plate

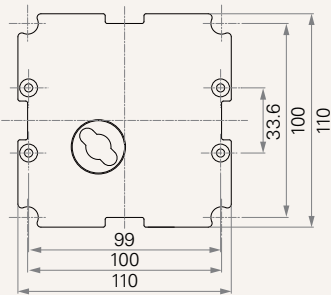

Tubes direction

0 = Thinner on top

1 = Wider on top

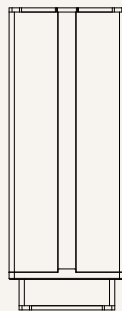
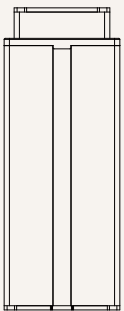

Terms of Use

The user is responsible for determining the suitability of TiMOTION products for a specific application. TiMOTION products are subject to change without prior notice.