

TA21

series



Product Segments

- **Care Motion**
- **Ergo Motion**
- **Industrial Motion**

TiMOTION's TA21 electric linear actuator was designed for use in height adjustable medical and industrial workstations. Customers have a high degree of design flexibility with this actuator as it does not include a standard outer tube. This allows manufacturers to decide on the exact aesthetic and ingress specifications for their electric lifting column and overall application.

General Features

Voltage of motor	24V DC
Maximum load	10,000N in push
Maximum load	6,000N in pull
Maximum speed at full load	16.2mm/s (with 4000N in a push or pull condition)
Stroke	25~400mm
Minimum installation dimension	≥ 67mm
Color	Black or grey
Options	Safety nut, Hall / Reed sensor(s)
Certificate	UL962

Drawing

Standard Dimensions
(mm)

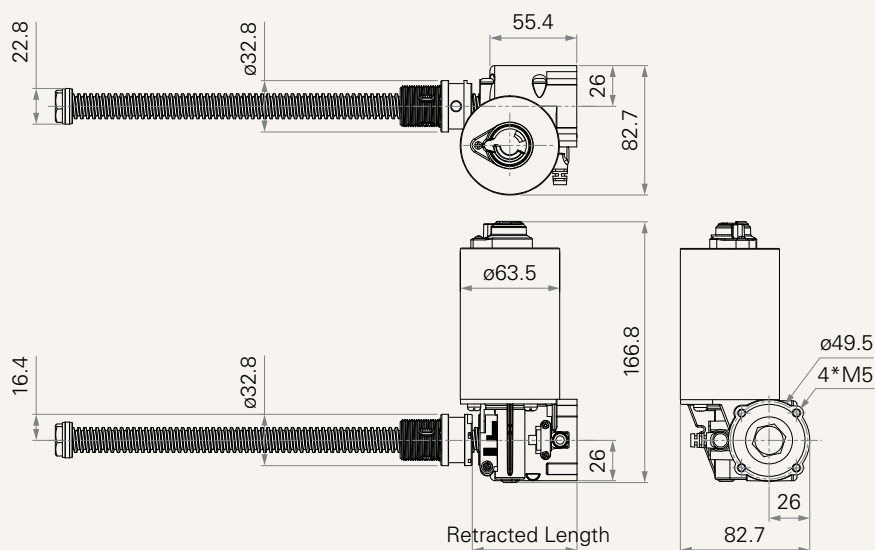

Retracted length L1, Min ≥ 67 mm (NO need to add stroke length)

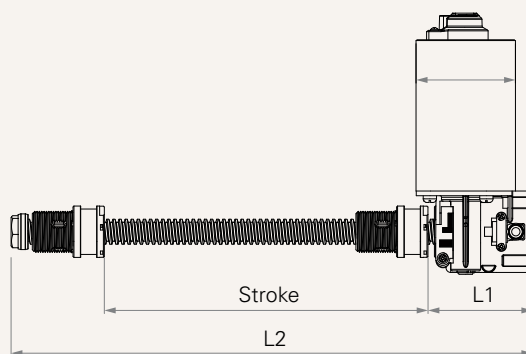

Load and Speed

CODE	Load (N)		Self Locking Force (N)	Typical Current (A)		Typical Speed (mm/s)	
	Push	Pull		No Load 24V DC	With Load 24V DC	No Load 24V DC	With Load 24V DC
Motor Speed (3800RPM, duty cycle 10%)							
A	10000	6000	10000	2.0	15.0	12.1	6.3
C	7000	6000	6000	2.0	9.0	12.3	8.3
D	4000	4000	3000	2.0	9.5	24.7	16.2

Note

- 1 Please refer to the approved drawing for the final authentic value.
- 2 This self-locking force level is reached only when a short circuit is applied on the terminals of the motor. All the TiMOTION control boxes have this feature built-in.
- 3 Operational temperature range: +5°C~+45°C
- 4 The current & speed in table are tested when the actuator is extending under push load.
- 5 The current & speed in table and diagram are tested with TiMOTION control boxes, and there will be around 10% tolerance depending on different models of the control box. (Under no load condition, the voltage is around 32V DC. At rated load, the voltage output will be around 24V DC)

Performance Data (24V DC Motor)

Motor Speed (3800RPM)

Speed vs. Load

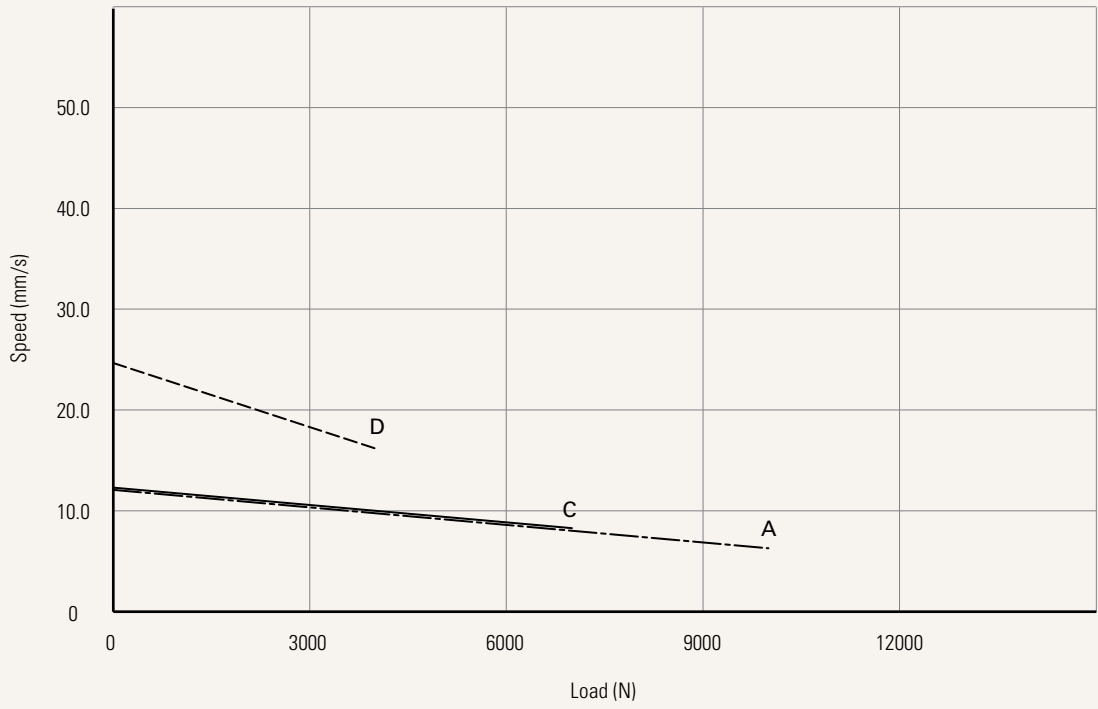

Current vs. Load

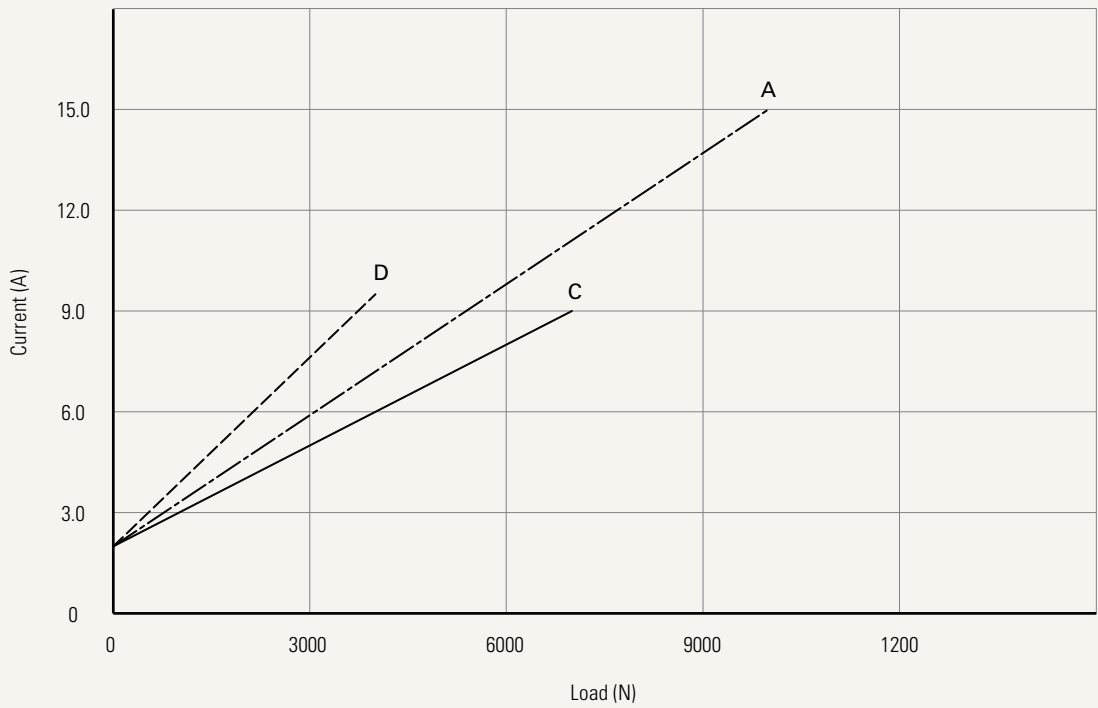

Voltage	2 = 24V DC		
Load and Speed	See page 2		
Stroke (mm)			
Retracted Length (mm)	See page 2		
Motor Cable Color	1 = Black	2 = Grey (Pantone 428C)	
Special Functions for Spindle Sub-Assembly	1 = Safety nut		
Output Signals	0 = Without	2 = Hall sensors*2	3 = Reed Sensor
Connector See page 5	1 = DIN 6P, 90° plug	2 = Tinned leads	F = DIN 6P, 180° plug
Cable Length (mm)	1 = Straight, 500 2 = Straight, 750	3 = Straight, 1000 4 = Straight, 1250	5 = Straight, 1500 6 = Straight, 2000 7 = Curly, 200 8 = Curly, 400

Connector

1 = DIN 6P, 90° plug

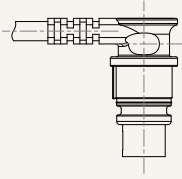

2 = Tinned leads

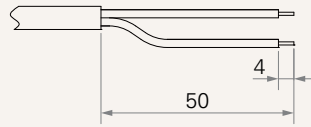

F = DIN 6P, 180° plug

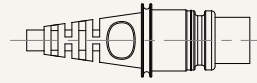

Terms of Use

The user is responsible for determining the suitability of TiMOTION products for a specific application. TiMOTION products are subject to change without prior notice.