

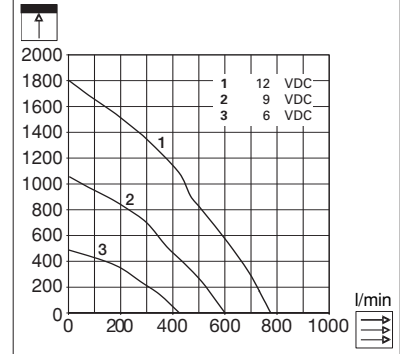

Miniatur Radial Gebläse
Miniature Radial Blower
Ventilateur miniature radial



U97DR-012KK-4 12 VDC



U97DR-024KK-4 24 VDC

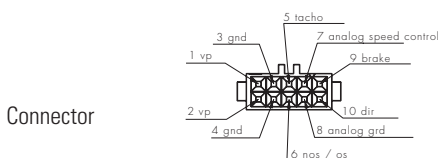
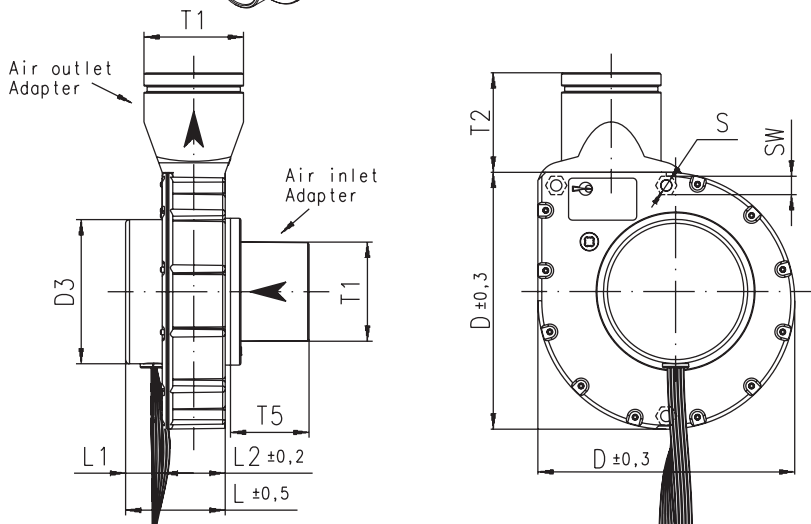
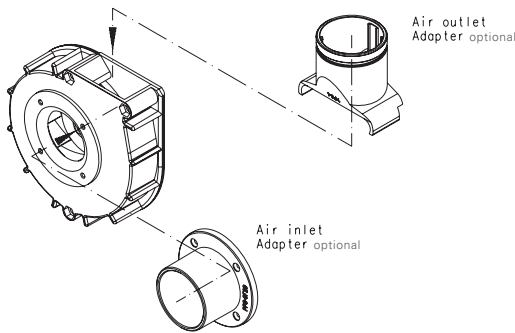
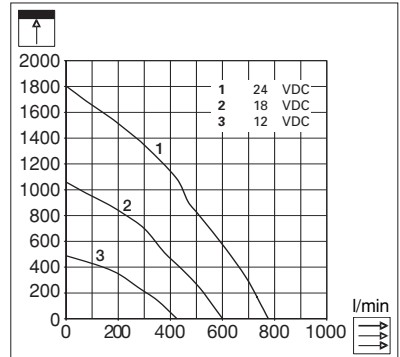

Typ: Tyco V23535-328-101

U97DR	mm	inch
D	98	3.858
D3	∅ 55	∅ 2.170
L	38	1.500
L1	14	0.550
L2	24	0.940
S	∅ 4.3	∅ 0.169
SW	7.0	0.276
T1	∅ 38	∅ 1.496
T2	38	1.496
T5	30	1.181

Technische Daten

Technical data

Caractéristiques techniques

Die U97DR-Baureihe ist mit einem bürstenlosen Motor mit integrierter Elektronik ausgerüstet.

- Flachmotor / Discmotor
- hohe Laufzeit
- integrierter Temperaturschutz (Motor)
- Tachosignal (Drehzahlrückmeldung)
- NOS (Non Operating Signal)
- analog speed control
- 24 V DC-Ausführung ohne Strombegrenzung

The U97DR-serie is equipped with brushless motor with integrated electronic.

- flat motor / disc motor
- long operation time
- integrated temperature monitoring
- tacho signal (speed indicator)
- NOS (Non Operating Signal)
- analog speed control
- 24 V DC version without current limites

La série U97DR est équipée avec un moteur "brushless" avec électronique intégrée.

- moteur plat / moteur à disque
- long temps d'usage
- surveillance de température intégrée
- signal tacho (tachomètre)
- NOS (Non Operating Signal)
- analog speed control
- Execution 24 V sans limitation de courant

			U97DR-012KK-4	U97DR-024KK-4	
U	U_N	V	12	24	
	U	V	6 - 13.5	16 - 27	
I		mA	1'690	850	
I	I_N	mA	1'570	800	
I		mA	990	480	
	I_{block}	A	6,8	–	
P		P_N	W	18.9	19.2
	n	min^{-1}	14'600	15'150	
	n_N	min^{-1}	14'900	15'400	
	n	min^{-1}	16'670	16'810	
	\dot{V}	l/min;CFM	780/27.56	790/27.92	
	\dot{V}	l/min;CFM	420/14.84	390/13.78	
	p	Pa	1'090	1'220	
	p	Pa	1'800	1'930	
	LpA	dB(A)	67	69	
MTTF	MTTF	hr	40'000	40'000	
	T	°C/F	-20...+65/-5...+150	-20...+65/-5...+150	
	m	gr/oz.	170/6.69	170/6.69	
	Lead Length	mm	215±15 (AWG 26)	215±15 (AWG 26)	
	Housing Material		PPO UL-94V-1	PPO UL-94V-1	
	Sleeve Bearing		–	–	
	Ball Bearing		•	•	
	Tacho Signal		•	•	
	Inlet Adapter		optional	optional	
	Outlet Adapter		optional	optional	
	Explosion Protection		optional	–	
	Freiblasend		Free blowing	Refolement libre	
	Prüfearbeitspunkt bei ca. 50% Luftmenge		Inspection working point at approx. 50% air vol.	Point de travail de contrôle appr. à 50% volume d'air	
	Druckerhöhung statisch		Pressure difference static	Différence de pression statique	

Specifications are subject to change without notice. Specifications on this Datasheet are for reference.

Instructions for U-Line 10 Lead Version

(disc motor U97DR, U150R)

Power supply requirements and Blower operating

The power supply must limit the current according the absolute maximum ratings !!!

Absolute maximum ratings

	U97DR		U150R	
	12 V	24 V	12 V	24 V
Blower voltage range Ripple < 5 %	8...16 V	12...27 V	8...16 V	12...27 V
Power supply minimal current	3 ADC	2 ADC	3 ADC	3 ADC
Current limit maximal at the power supply	7 ADC	4 ADC	7 ADC	5 ADC
Maximal Blower operating current	2.4 ADC	2.4 ADC	2.4 ADC	2.4 ADC*
Blower locked rotor protection	yes	no	yes	no
Use of BRAKE function allowed	yes	no	yes	no

* max. current 2 ADC at 27 V

The values are measured at 25°C / 77°F

Exceeding the absolute maximum ratings may cause permanent damage.

Instructions for U-Line 10 Lead Version

(disc motor U97DR, U150R)

Connector pre-connection

External 470µF / 35 V capacitor is necessary
Pin 1 and 2 to 3 and 4 (near the connector)

U97DR 24V: pre-connect Poly – Switch Tyco RXE110 to Pin 1 / 2 !

Connector:

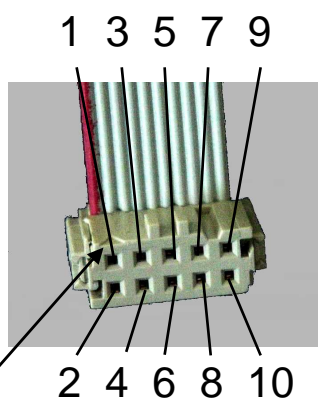

1 VP	6 NOS
2 VP	7 Van
3 GND	8 AN. GND
4 GND	9 Brake
5 Tacho	10 nc

notice arrow (Pin 1)

Pin 1 / 2 VP power supply positive potential
Pin 1 and 2 must be connected
470µF / 35 V capacitor is necessary Pin 1 and 2 to 3 and 4

Pin 3 / 4 GND power supply ground potential
Pin 3 and 4 must be connected

Pin 5 Tacho Open drain output: pull-up resistor (22kΩ) to 5V is **integrated**.
(max. 10mA, no direct connection to GND and +VP)
 $f_{Tacho} [Hz] * 5 = rpm [1/min]$ (8 pol. Motor)

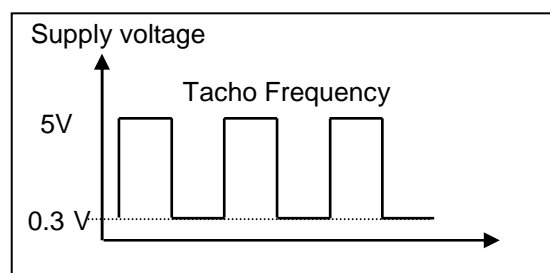

Instructions for U-Line 10 Lead Version

(disc motor U97DR, U150R)

Pin 6 NOS **Non Operating Signal**
 Open drain output: pull-up resistor (22kΩ) to 5V is **integrated**.
 (max. 10mA, no direct connection to GND and +VP)
 motor run: low motor blocked: high

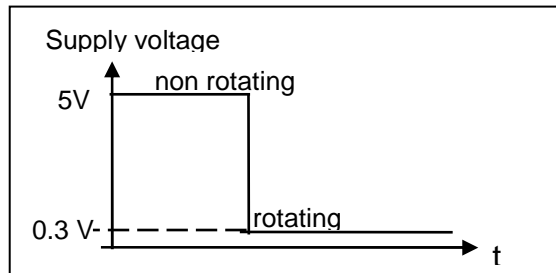

Pin 7 Van **Analog speed control** **Input: 0...5 VDC**
 Potentiometer 100kΩ to be connected with AN. GND (Pin 8) .

$$U_{V5V} = 5V$$

$$PWM \ U_{Motor} = \frac{U_{V5V} * R_{PWMpoti} * 8.75}{(15\ k\Omega + R_{PWMpoti})}$$

R 15 kΩ is integrated.
(pull-up resistor to 5V)

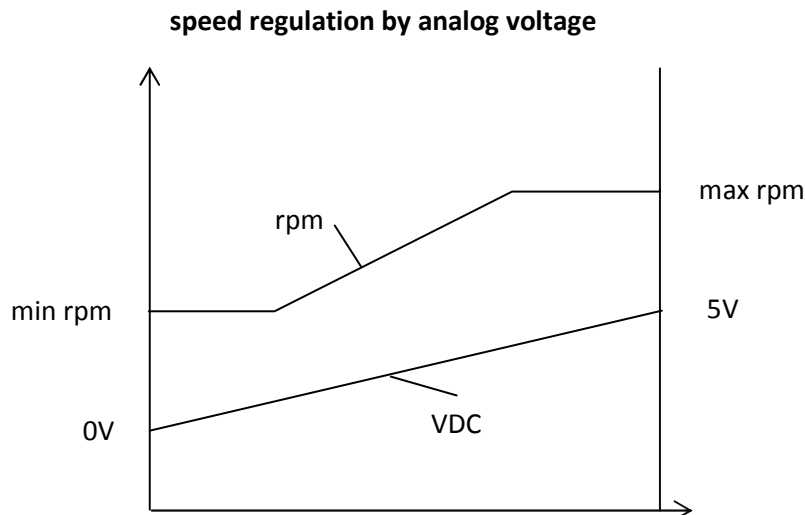

U Motor = U Pin Van * 8.75 (Independent of supply voltage)

Without Pin 7 connection: motor rotate with 100 % speed

Instructions for U-Line 10 Lead Version

(disc motor U97DR, U150R)

Pin 9	Brake	At activated Brake signal, the motor is stopped immediately by shorting all driver outputs to ground. $U_{\max} = 5V$ (rotate) $U < 0.3 V = \text{blocked}$
Pin 10	nc	please do not use $U_{\max} = 5V$

Caution



- **Handle connector only in currentless condition.**
- **no polarity protection**
- **power supply must limit the current !**
(please see chart at page nr. 1)