

SPECIFICATION	CONNECTION	BIPOLAR
VOLTAGE (VDC)		1.9
AMPS/PHASE		3.0
RESISTANCE/PHASE (Ohms)@25°C		0.63±15%
INDUCTANCE/PHASE (mH) @1KHz		1.03±20%
HOLDING TORQUE (Nm) [lb-in]		0.5 [4.43]
DETENT TORQUE (Nm) [lb-in]		2.2x10 <sup>-2</sup> [0.2]
STEP ANGLE (°)		1.8
STEP ACCURACY (NON-ACCUM)		±5%
ROTOR INERTIA (Kg-m <sup>2</sup> ) [lb-in <sup>2</sup> ]		8.2x10 <sup>-6</sup> [2.8x10 <sup>-2</sup> ]
WEIGHT (Kg) [lb]		0.34 [0.77]

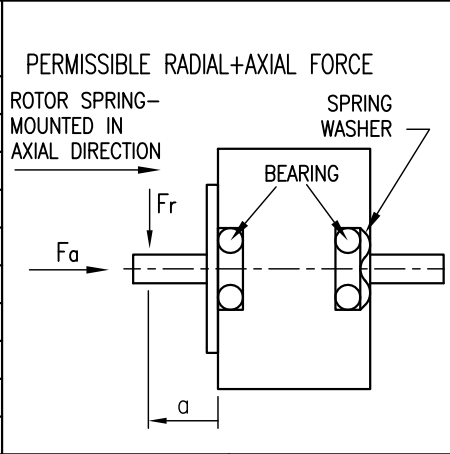

PIN NO	TYPE OF CONNECTION (EXTERN)		MOTOR	
	BIPOLAR	LEADS	WINDING	
1	A —	BRN	A	
2	A \ —	ORG	A \	
3	B —	RED	B	
4	B \ —	YEL	B \	

TEMPERATURE RISE: MAX.80°C (MOTOR STANDSTILL; FOR 2 PHASE ENERGIZED)	AXIAL-FORCE Fa (N)	Fa=7			
AMBIENT TEMPERATURE -10°~ 50°C [14°F ~ 122°F]	DISTANCE a (mm)	5	10	15	20
INSULATION RESISTANCE 100 MOhm (UNDER NORMAL TEMPERATURE AND HUMIDITY)	RADIAL-FORCE Fr (N)	58	36	26	20
INSULATION CLASS B 130° [266°F]		AXIAL		RADIAL	
DIELECTRIC STRENGTH 500VAC FOR 1 MIN. (BETWEEN THE MOTOR COILS AND THE MOTOR CASE)	SHAFT PLAY (mm)	0.08		0.02	
AMBIENT HUMIDITY MAX. 85% (NO CONDENSATION)	AT LOAD MAX: (N)	4.5		4.5	

FULL STEP 2 PHASE-Ex., WHEN FACING MOUNTING END (X)

STEP	A	B	A \	B \	CCW	CW
1	+	+	-	-	↓	↑
2	-	+	+	-	↓	↑
3	-	-	+	+	↓	↑
4	+	-	-	+	↓	↑

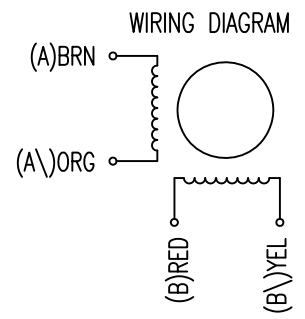

2	change motor length/ AWG	01.06.16	A.S.				APVD	<i>S.Ha.</i>	17.03.10	<b>STEPPING MOTOR</b>
1	rework draw/change depth M3	10.02.16	A.S.				CHKD			
REV	DESCRIPTION	DATE	DRN	Surface specification DIN ISO 1302	General tolerances DIN ISO 2768- cH	Work piece edge DIN ISO 13715	DRN	<i>J.W.</i>	17.03.10	DWG.NO ST4118L3004-A
							SIGNATURE	DATE		