

Front view and mounting

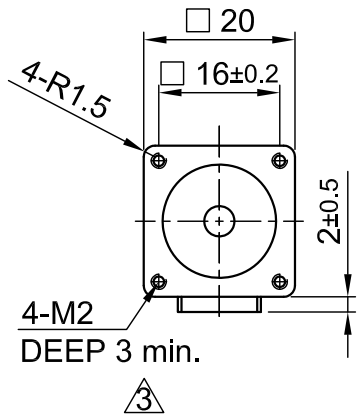

Side view

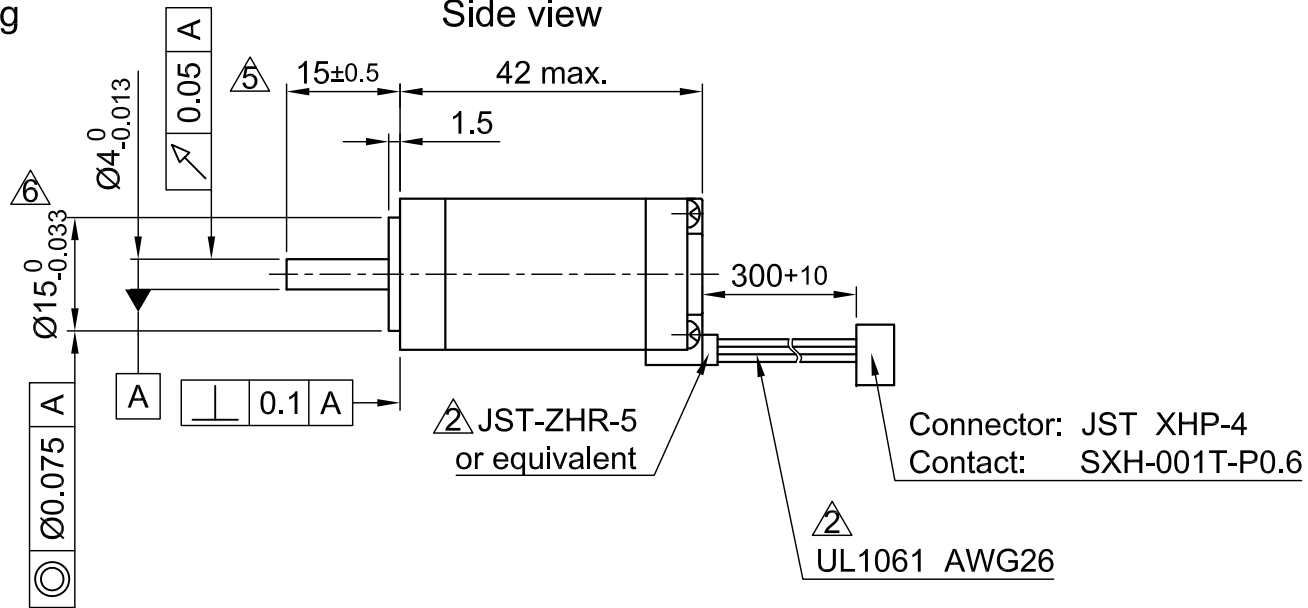

Rear view

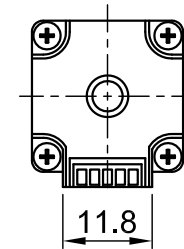

SPECIFICATION	BIPOLAR
VOLTAGE (VDC)	4.3
AMPS/PHASE	0.8
RESISTANCE/PHASE (Ohms)@25°C	5.4±15%
INDUCTANCE/PHASE (mH) @1KHz	1.5±20%
HOLDING TORQUE (Nm) [lb-in]	0.03 [0.265]
DETENT TORQUE (Nm) [lb-in]	1.5x10 <sup>-3</sup> [0.013]
STEP ANGLE (°)	1.8
STEP ACCURACY (NON-ACCUM)	±5%
ROTOR INERTIA (Kg-m <sup>2</sup> ) [lb-in <sup>2</sup> ]	3.6x10 <sup>-7</sup> [12.3x10 <sup>-4</sup> ]
WEIGHT (Kg) [lb]	0.08 [0.176]

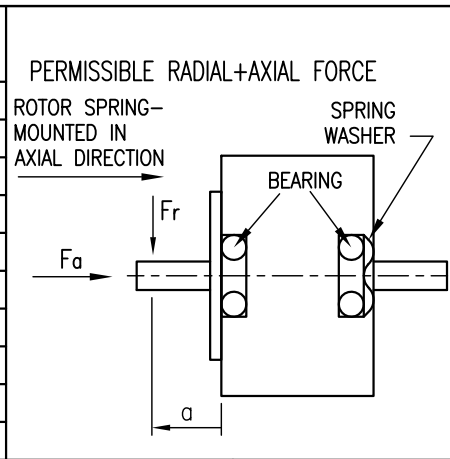

TYPE OF CONNECTION (EXTERN)	MOTOR			
	BIPOLAR	CONNECTOR PIN NO.	LEADS	WINDING
A —	1	BLK	A	
A\ —	2	GRN	A\	
B —	3	RED	B	
B\ —	4	BLU	B\	

FULL STEP 2 PHASE-Ex., WHEN FACING MOUNTING END (X)

STEP	A	B	A\	B\	CCW	CW
1	+	+	-	-	↓	↑
2	-	+	+	-	↑	↓
3	-	-	+	+	↓	↑
4	+	-	-	+	↑	↓

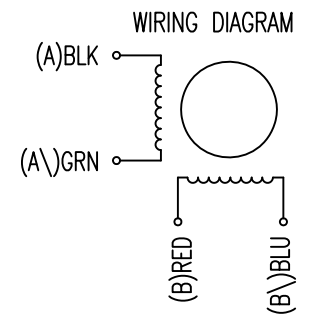

TEMPERATURE RISE: MAX.80°C (MOTOR STANDSTILL; FOR 2 PHASE ENERGIZED)	AXIAL-FORCE Fa (N)	Fa=4			
AMBIENT TEMPERATURE -10~ 50°C [14°F ~ 122°F]	DISTANCE a (mm)	5	10	15	20
INSULATION RESISTANCE 100 MOhm (UNDER NORMAL TEMPERATURE AND HUMIDITY)	RADIAL-FORCE Fr (N)	30	18	14	8
INSULATION CLASS B 130° [266°F]		AXIAL		RADIAL	
DIELECTRIC STRENGTH 500VAC FOR 1 MIN. (BETWEEN THE MOTOR COILS AND THE MOTOR CASE)	SHAFT PLAY (mm)	0.075		0.025	
AMBIENT HUMIDITY MAX. 85% (NO CONDENSATION)	AT LOAD MAX: (N)	10		5.0	

6	CHANGE TOLERANCE ø15/REWORK DRAW	24.02.16	A.S.
5	CHANGE TOLERANCE	06.12.13	J.D.
4	NEW VALUE OF ROTOR INERTIA	25.10.13	J.D.
REV	DESCRIPTION	DATE	DRN

**Nanotec**  
PLUG & DRIVE

Surface specification DIN ISO 1302	General tolerances DIN ISO 2768- cH	Work piece edge DIN ISO 13715
---------------------------------------	--	----------------------------------

APVD	S.K.	02.06.06
CHKD		
DRN	J.W.	02.06.06
SIGNATURE	DATE	

**STEPPING MOTOR**

DWG.NO  
ST2018M0804-A