

Front view and mounting

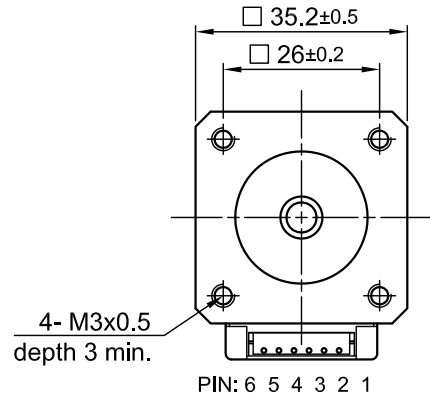

Side view

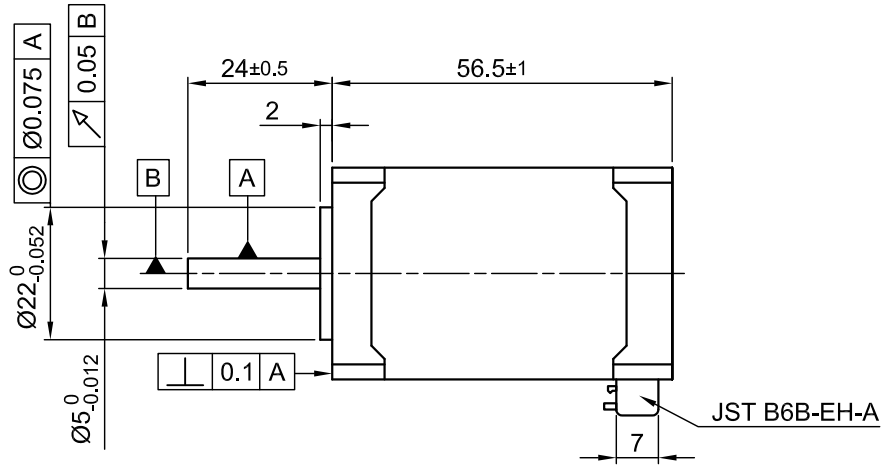

Rear view

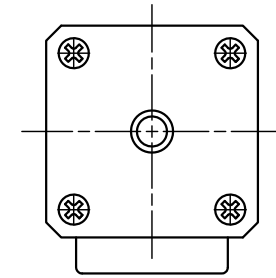

SPECIFICATION	CONNECTION	BIPOLAR SERIES
VOLTAGE (VDC)		4.56
AMPS/PHASE		1.2
RESISTANCE/PHASE (Ohms)@25°C		3.8±10%
INDUCTANCE/PHASE (mH) @1KHz		5.2±20%
HOLDING TORQUE (Nm) [lb-in]		0.32 [2.832]
DETENT TORQUE (Nm) [lb-in]		TBD
STEP ANGLE (°)		1.8
ACCURACY (NON-ACCUM)		±5%
ROTOR INERTIA (Kg-m <sup>2</sup> ) [lb-in <sup>2</sup> ]		4.3x10 <sup>-6</sup> [0.015]
WEIGHT (Kg) [lb]		0.3 [0.7]
TEMPERATURE RISE: MAX.80°C (MOTOR STANDSTILL; FOR 2 PHASE ENERGIZED)		
AMBIENT TEMPERATURE -10°~ 50°C [14°F ~ 122°F]		
INSULATION RESISTANCE 100 MOhm (UNDER NORMAL TEMPERATURE AND HUMIDITY)		
INSULATION CLASS B 130° [266°F]		
DIELECTRIC STRENGTH 500VAC FOR 1 MIN. (BETWEEN THE MOTOR COILS AND THE MOTOR CASE)		
AMBIENT HUMIDITY MAX. 85% (NO CONDENSATION)		

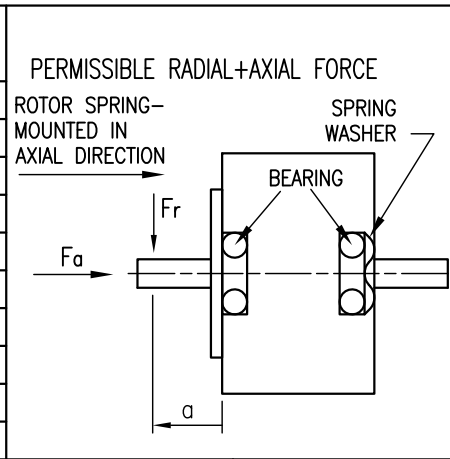

AXIAL-FORCE Fa (N)	Fa=7			
DISTANCE a (mm)	5	10	15	20
RADIAL-FORCE Fr (N)	58	36	26	20
		AXIAL	RADIAL	
SHAFT PLAY (mm)	0.08	0.02		
AT LOAD MAX: (N)	4.5	4.5		

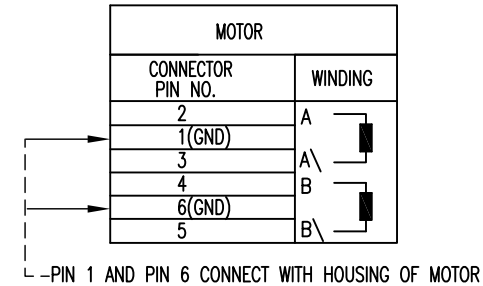

FULL STEP 2 PHASE-Ex., WHEN FACING MOUNTING END (X)

STEP	A	B	A\	B\	CCW	CW
1	+	+	-	-	↓	↑
2	-	+	+	-	↑	↓
3	-	-	+	+	↓	↑
4	+	-	-	+	↑	↓

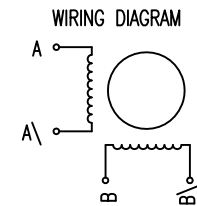

				<b>Nanotec</b> <sup>®</sup> PLUG & DRIVE			APVD	G.S.	19.03.15	<b>STEPPING MOTOR</b>
				Surface specification DIN ISO 1302	General tolerances DIN ISO 2768- cH	Work piece edge DIN ISO 13715	CHKD			
REV	DESCRIPTION	DATE	DRN				DRN	A.S.	18.03.15	DWG.NO
							SIGNATURE		DATE	SC3518L1204-A