

Front view and mounting

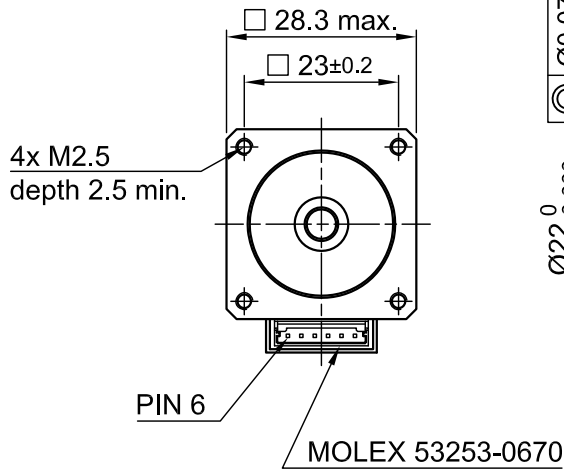

Side view

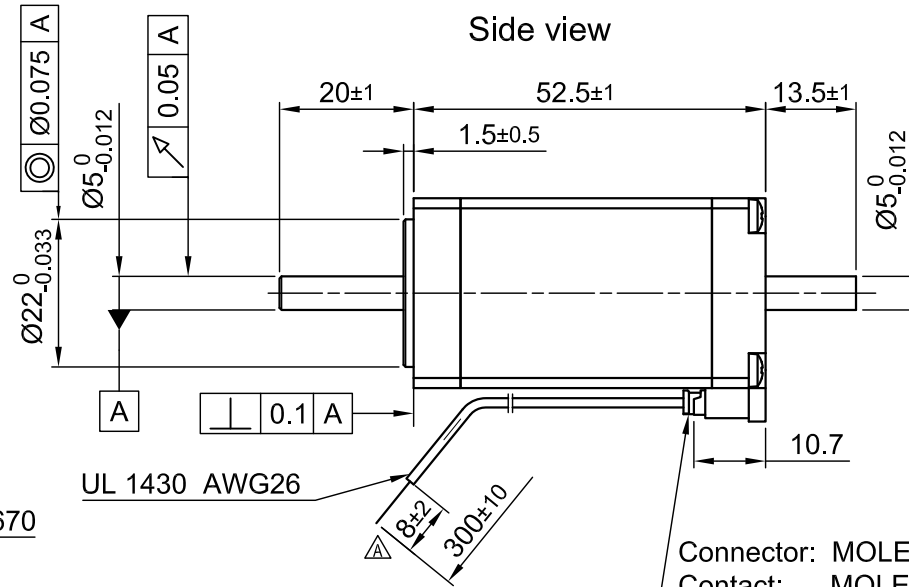

Rear view

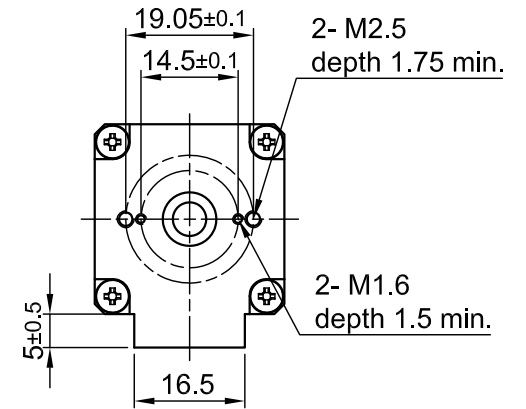

Connector: MOLEX 51065-0600
Contact: MOLEX 50212-8000

SPECIFICATION	CONNECTION	BIPOLAR SERIES
VOLTAGE (VDC)		2.7
AMPS/PHASE		1.5
RESISTANCE/PHASE (Ohms)@20°C		1.9±10% Δ
INDUCTANCE/PHASE (mH) @1KHz		1.9±20% Δ
HOLDING TORQUE (Nm) [lb-in]		0.18 [1.58]
STEP ANGLE (°)		1.8
ACCURACY (NON-ACCUM)		±5%
ROTOR INERTIA (Kg-m ²) [lb-in ²]		1.8x10 ⁻⁶ [0.0061]
WEIGHT (Kg) [lb]		0.2 [0.44]
TEMPERATURE RISE: MAX.80°C		
ATTN: MAKE SURE TEMPERATURE OF MOTOR CASE REMAINS BELOW 100°C		
AMBIENT TEMPERATURE -20°~ +50°C [-4°F ~ 122°F]		
INSULATION RESISTANCE 100 MOhm (UNDER NORMAL TEMPERATURE AND HUMIDITY)		
INSULATION CLASS B 130° [266°F]		
DIELECTRIC STRENGTH 500VAC FOR 1 MIN. (BETWEEN THE MOTOR COILS AND THE MOTOR CASE)		
AMBIENT HUMIDITY MAX. 85% (NO CONDENSATION)		

PERMISSIBLE RADIAL+AXIAL FORCE

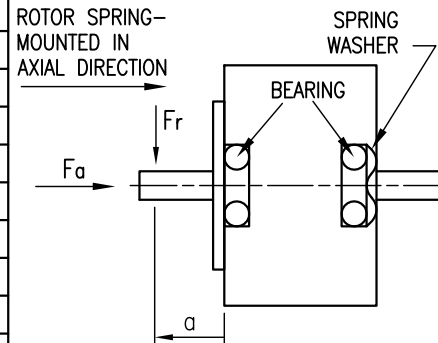

AXIAL-FORCE Fa (N)	Fr	
Fa=7		
DISTANCE a (mm)	Fr (N)	
5	28 max.	
	AXIAL	RADIAL
SHAFT PLAY (mm)	0.08	0.02
AT LOAD MAX. (N)	4	4

TYPE OF CONNECTION (EXTERN)	MOTOR			
	BIPOLAR	CONNECTOR PIN NO.	LEADS	WINDING
A —	1	BK	A	
A\ —	3	GN	A\	
B —	4	RD	B	
B\ —	6	BU	B\	

FULL STEP 2 PHASE-Ex., WHEN FACING MOUNTING END (X)

STEP	A	B	A\	B\	CCW	CW
1	+	+	-	-	↓	↑
2	-	+	+	-	↑	↓
3	-	-	+	+	↓	↑
4	+	-	-	+	↑	↓

WIRING DIAGRAM

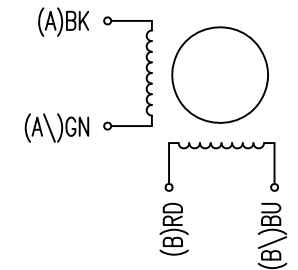

REV	DESCRIPTION	DATE	DRN	Surface specification DIN ISO 1302			General tolerances DIN ISO 2768- cH			Work piece edge DIN ISO 13715			SIGNATURE		DATE		DWG.NO		
B	-	26.10.17	A.S.	Nanotec® PLUG & DRIVE			APVD			G.S.		19.07.16		STEPPING MOTOR					
A	-	23.10.17	G.S.				CHKD			DRN		A.S.		14.07.16		DWG.NO			
														SC2818L1504-B					