

Front view and mounting

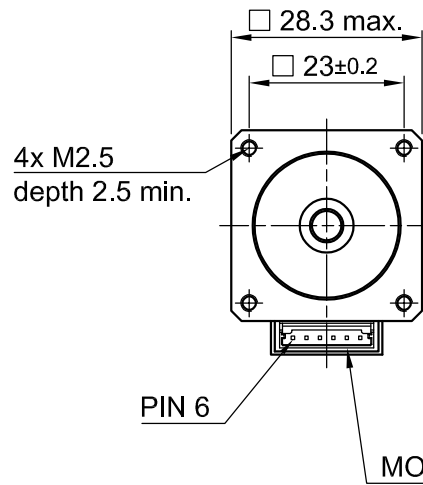

Side view

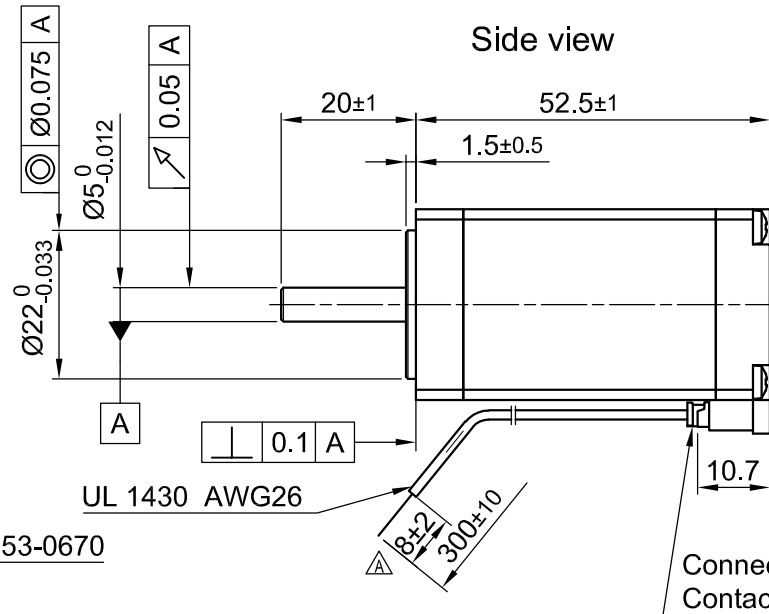

Rear view

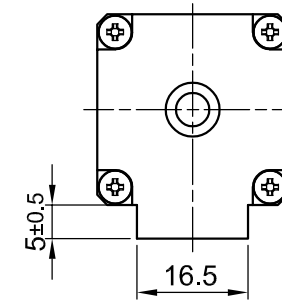

Connector: MOLEX 51065-0600
Contact: MOLEX 50212-8000

SPECIFICATION	CONNECTION	BIPOLAR SERIES
VOLTAGE (VDC)		6.2
AMPS/PHASE		0.67
RESISTANCE/PHASE (Ohms)@20°C		9.2±10%
INDUCTANCE/PHASE (mH) @1KHz		8.4±20%
HOLDING TORQUE (Nm) [lb-in]		0.18 [1.58]
STEP ANGLE (°)		1.8
ACCURACY (NON-ACCUM)		±5%
ROTOR INERTIA (Kg-m ²) [lb-in ²]		1.8x10 ⁻⁶ [0.0061]
WEIGHT (Kg) [lb]		0.2 [0.44]
TEMPERATURE RISE: MAX.80°C		
ATTN: MAKE SURE TEMPERATURE OF MOTOR CASE REMAINS BELOW 100°C		
AMBIENT TEMPERATURE -20°~ +50°C [-4°F ~ 122°F]		
INSULATION RESISTANCE 100 MOhm (UNDER NORMAL TEMPERATURE AND HUMIDITY)		
INSULATION CLASS B 130° [266°F]		
DIELECTRIC STRENGTH 500VAC FOR 1 MIN. (BETWEEN THE MOTOR COILS AND THE MOTOR CASE)		
AMBIENT HUMIDITY MAX. 85% (NO CONDENSATION)		

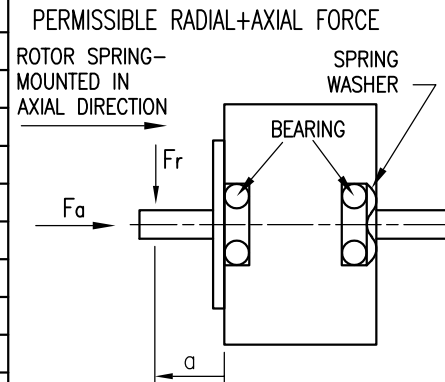

PERMISSIBLE RADIAL+AXIAL FORCE	ROTOR SPRING-MOUNTED IN AXIAL DIRECTION	SPRING WASHER	BEARING
AXIAL-FORCE Fa (N)			Fr
DISTANCE a (mm)			a
RADIAL-FORCE Fr (N)			
	AXIAL	RADIAL	
SHAFT PLAY (mm)	0.08	0.02	
AT LOAD MAX. (N)	4	4	

TYPE OF CONNECTION (EXTERN)	MOTOR			
	BIPOLAR	CONNECTOR PIN NO.	LEADS	WINDING
A —	1	BK	A	[Circuit diagram showing A and A\ windings]
A\ —	3	GN	A\	
B —	4	RD	B	[Circuit diagram showing B and B\ windings]
B\ —	6	BU	B\	

FULL STEP 2 PHASE-Ex., WHEN FACING MOUNTING END (X)

STEP	A	B	A\	B\	CCW	CW
1	+	+	-	-	↓	↑
2	-	+	+	-	↑	↓
3	-	-	+	+	↓	↑
4	+	-	-	+	↑	↓

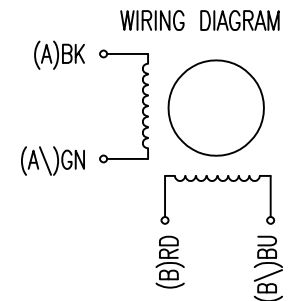

				Nanotec PLUG & DRIVE			APVD	G.S.	19.07.16	STEPPING MOTOR
				Surface specification DIN ISO 1302	General tolerances DIN ISO 2768- cH	Work piece edge DIN ISO 13715	CHKD			
A	-	23.10.17	G.S.				DRN	A.S.	14.07.16	DWG.NO
REV	DESCRIPTION	DATE	DRN				SIGNATURE		DATE	SC2818L0604-A