

PGRH SERIES

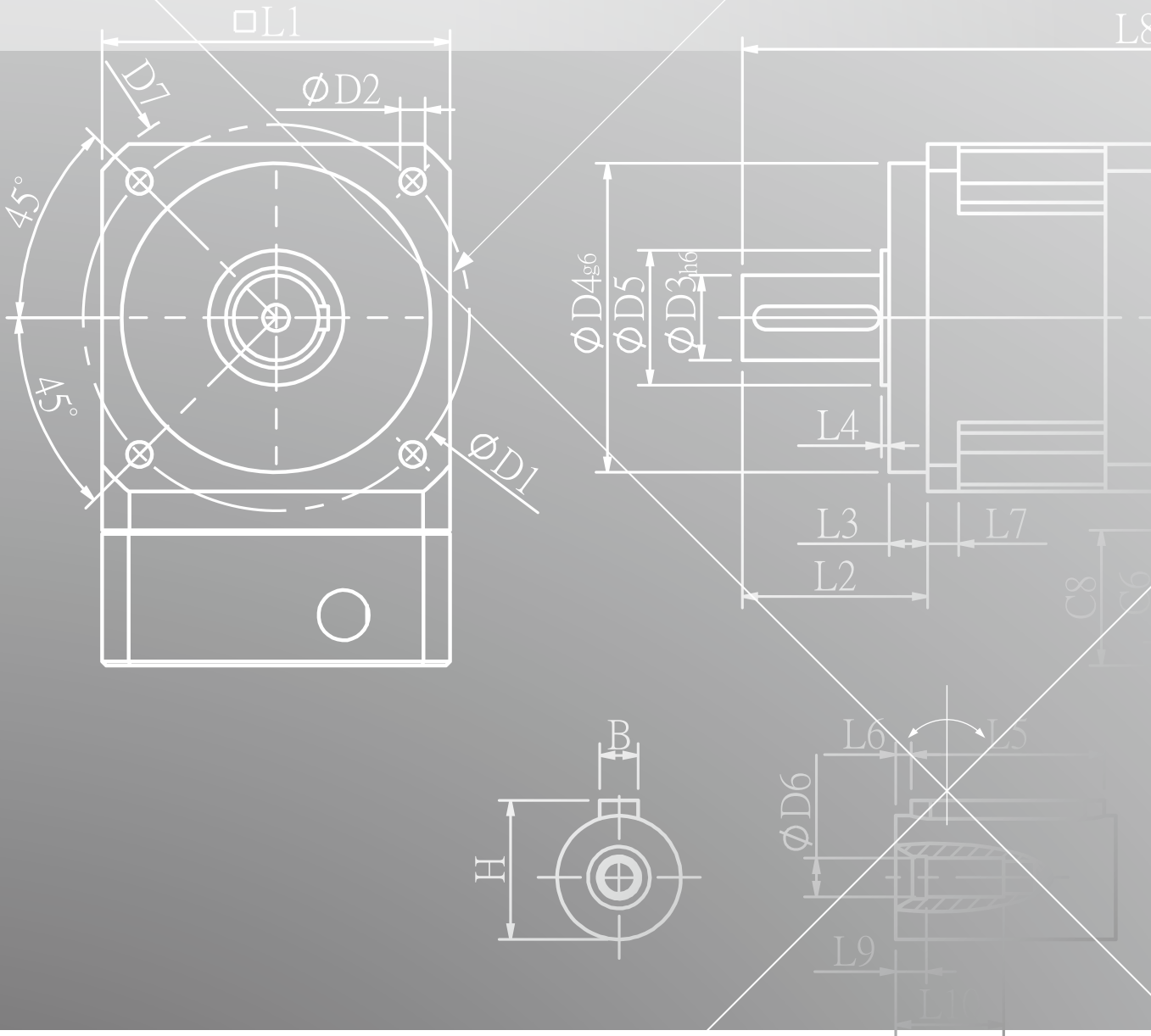

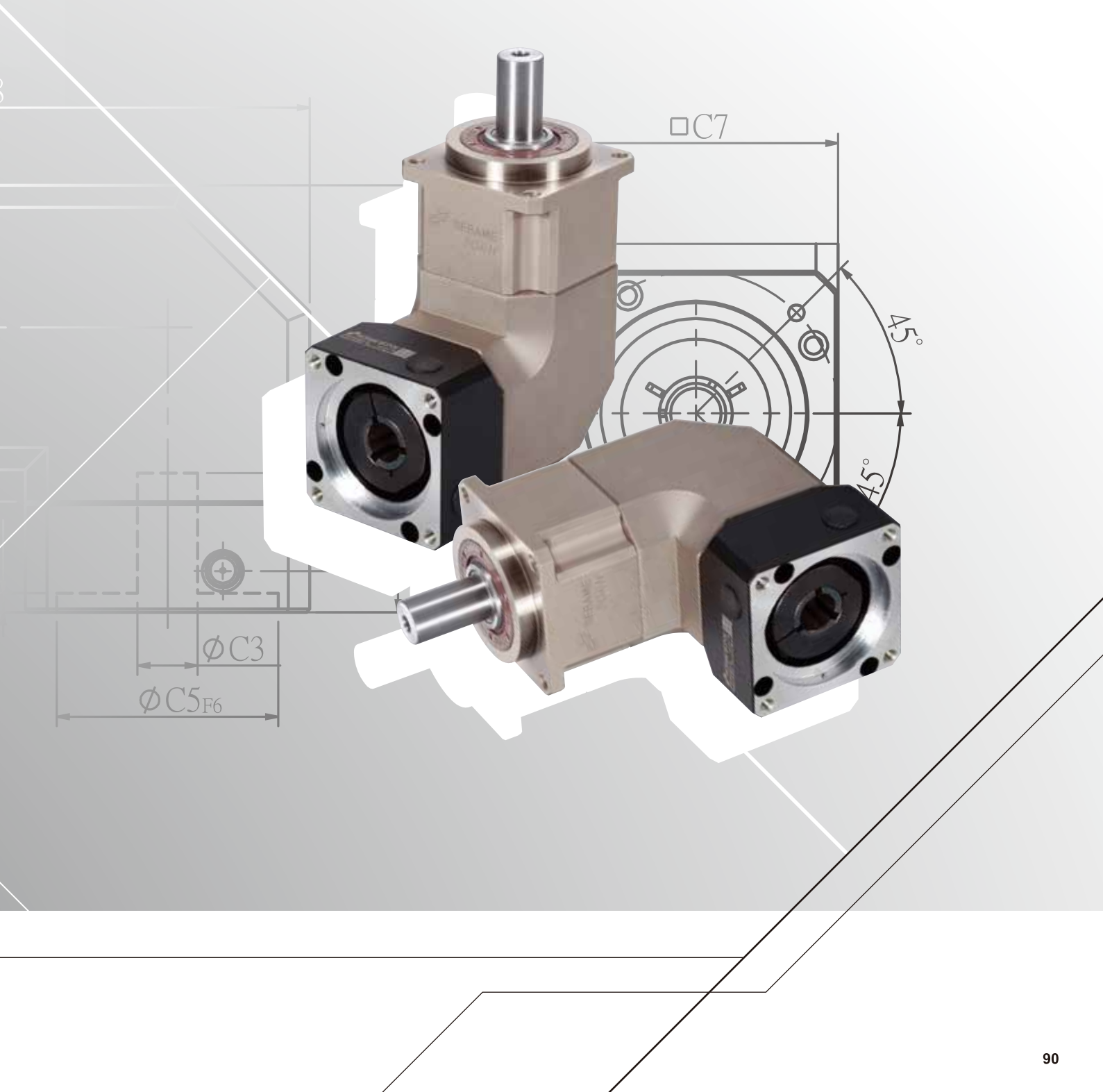

PGRH SERIES FEATURES

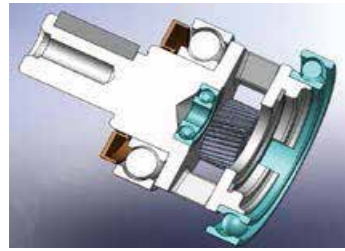

Planetary arm bracket and output shaft are one-piece constructed, setting bearing apart for larger span to reach the largest reverse rigid and contribute high axis radial load capacity.



Alloy steel gear with unique heat treatment. Additionally, with gear grinding processing to get the best accuracy, high wear resistance and high impact toughness.

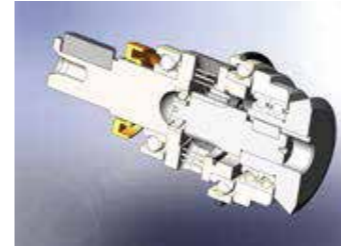

The sun gear bearing is placed directly into the planetary arm bracket, the overall mechanical structure designed to ensure concentricity of the transmission components.



Alloy steel spiral bevel gears selected after hobbing and heat treatment to ensure high accuracy of the engagement point, low backlash and low noise.

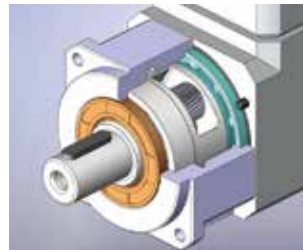

Grinding process to smooth surface of output shaft, and with oil-seal to minimum friction coefficient and reducing start up load; result in the best seal-ability and extended lifespan.

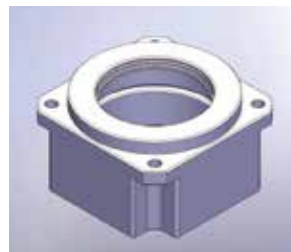

Advanced electroless nickel plating surface treatment resists scratch and corrosion. Suitable for stringent require of high-tech equipment. The gear box and internal gear ring are one-piece constructed, and then processed with advanced Germany gear shaper machinery for high-precision, high torque and abrade consumption.

PGRH Series overall design suitable for combination operation with servo motor high-speed input and achieves maximum torque output. Right-angular designed drastically reducing the installation space. Precision gear design and gear processing create a planetary gearhead with low backlash operation, high efficiency, low noise and long lifespan.

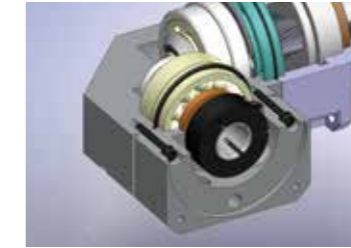
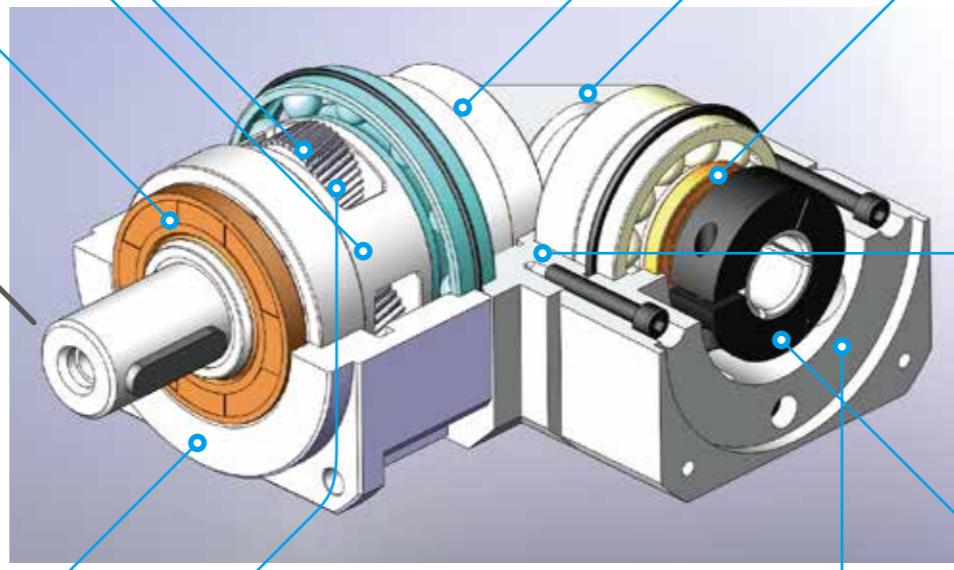

High-tech oil seal design on the upper lip guard against dust intruder, lower lip to guard against oil leak. Advanced lubricants grease and IP65 protection safeguards fully avoid leaking and given it maintenance-free.

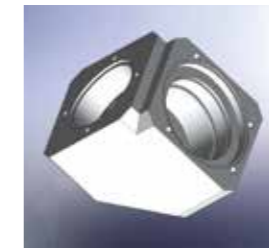

Right angular gear box processed by precision CNC equipment to obtain the highest combination with spiral bevel gears. Advanced electroless nickel plating surface treatment resists scratch and corrosion. Suitable for stringent require of high-tech equipment.

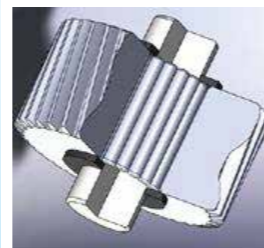

Planet gear transmission interface equipped with needle bearings, full needle roller bearings aligned without retainer achieve maximum exposure but smallest gap tolerances. Enhance over-all gear structure rigid and output torque.

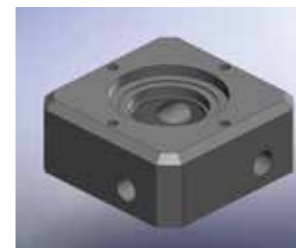

Advanced motor bracket design coupled with the input shaft bushing is easy to mount to any servo or stepper motor.

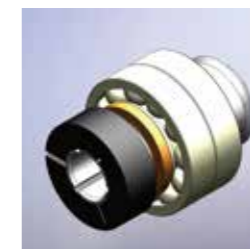

Input-end and motor shaft are coupled through a dynamic balanced collar clamping mechanism to ensure connection interface concentricity and zero slip power transmission at high speed.

Products due to human error, natural disasters or other factors lead to poor or damaged, will not be covered under warranty.

PHL
PHR
PI
PGH
PUR
PUL
PGLH
PCL
PGC
PGE
PGRH
PGR
PGFR
PGF
PBC
PBE
PAE
PAC
PAN
PGS
PNS

PGRH Single Stage Dimensions

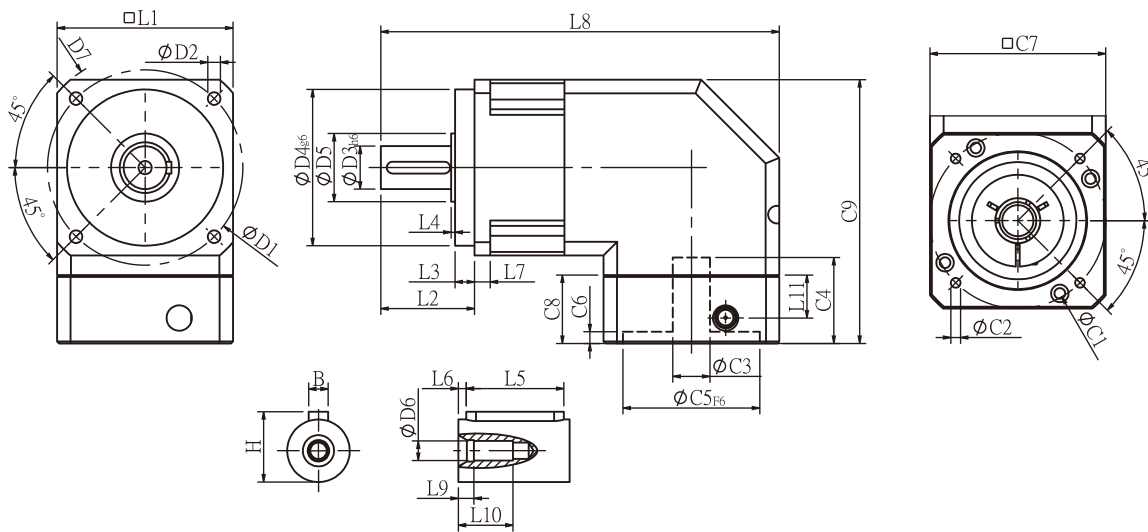

Specifications

Unit:mm

Dimensions	PGRH42	PGRH60	PGRH90	PGRH115	PGRH142
D1	50	70	100	130	165
D2	3.4	5.5	6.5	8.5	10.5
D3 h6	13	16	22	32	40
D4 g6	35	50	80	110	130
D5	15	25	35	45	50
D6	M4x0.7P	M5x0.8P	M8x1.25P	M12x1.75P	M16x2P
D7	56	80	118	148	186
L1	42.6	60	90	115	142
L2	26	37	48	63	91.5
L3	5.5	7	10	10	10
L4	1.5	1.5	1.5	3.5	3.5
L5	15	25	32	40	60
L6	2	2	3	5	5
L7	4	6	8	12	18
L8	103.6	148.2	204	246.5	325
L9	4	4	4.5	6	6
L10	14	16.5	20.5	30	38
L11	13.5	21.5	22	32	44.7
C1 ²	46	70	90	115	145
C2 ²	M4x0.7P	M5x0.8P	M6x1P	M8x1.25P	M8x1.25P
C3 ²	≤8	≤14	≤19/≤24	≤24/≤32	≤35
C4 ²	29	34	44	53	76
C5 ² F6	30	50	70	95	110
C6 ²	6	5	5	6	9
C7 ²	42.6	60	90	115	140
C8 ²	25	33	35	48	65
C9 ²	70.8	107.8	135	174.5	207
B	5	5	6	10	12
H	15	18	24.5	35	43

★ C1~C9 are motor specific dimensions(metric std shown). Size may vary according to the motor flange chosen.

★ Specification subject to change without notice.

PGRH Double Stage Dimensions-1

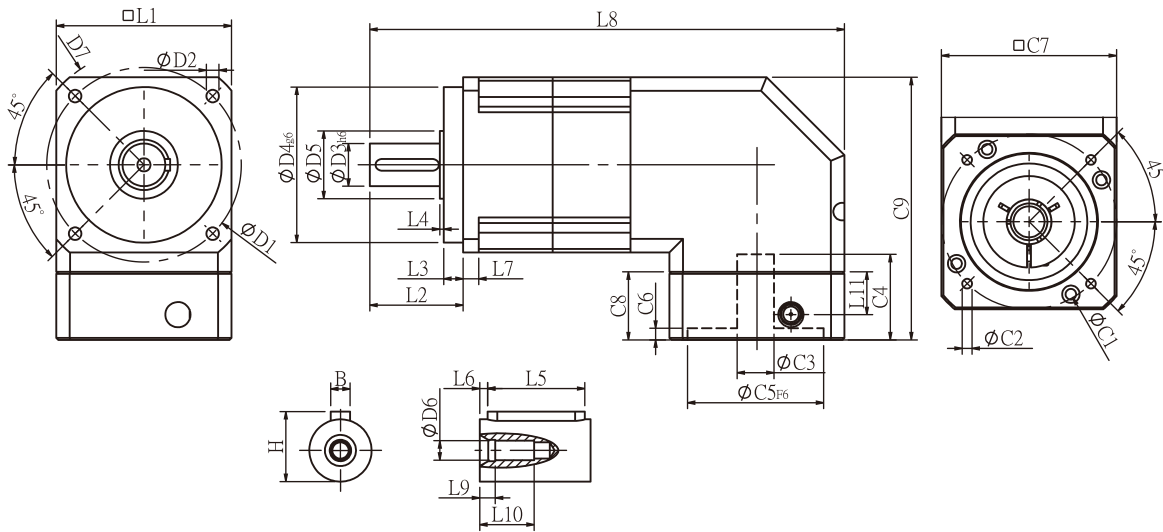

Specifications

Unit:mm

Dimensions	PGRH42	PGRH60	PGRH90
D1	50	70	100
D2	3.4	5.5	6.5
D3 ^{h6}	13	16	22
D4 ^{g6}	35	50	80
D5	15	25	35
D6	M4x0.7P	M5x0.8P	M8x1.25P
D7	56	80	118
L1	42.6	60	90
L2	26	37	48
L3	5.5	7	10
L4	1.5	1.5	1.5
L5	15	25	32
L6	2	2	3
L7	4	6	8
L8	130.6	181.2	248
L9	4	4	4.5
L10	14	16.5	20.5
L11	13.5	21.5	22
C1 ²	46	70	90
C2 ²	M4x0.7P	M5x0.8P	M6x1.0P
C3 ²	≤8	≤14	≤19/≤24
C4 ²	29	34	44
C5 ² F6	30	50	70
C6 ²	6	5	5
C7 ²	42.6	60	90
C8 ²	25	33	35
C9 ²	70.8	107.8	135
B	5	5	6
H	15	18	24.5

* C1~C9 are motor specific dimensions(metric std shown), Size may vary according to the motor flange chosen.

* Specification subject to change without notice.

PGRH Double Stage Dimensions-2

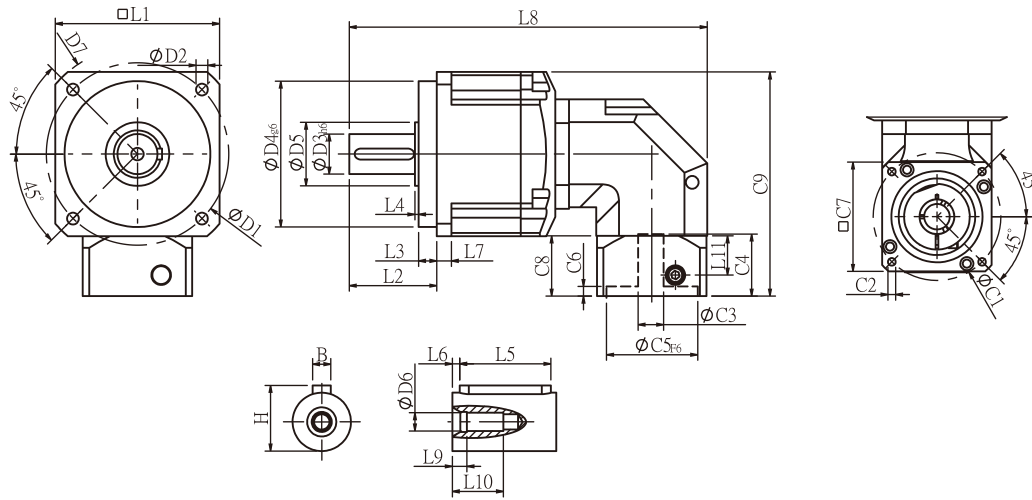

Specifications

Unit:mm

Dimensions	PGRH60T	PGRH90T	PGRH115T	PGRH142T	PGRH180T	PGRH220T
D1	70	100	130	165	215	-
D2	5.5	6.5	8.5	10.5	13	-
D3 _{h6}	16	22	32	40	55	-
D4 _{g6}	50	80	110	130	160	-
D5	25	35	45	50	70	-
D6	M5x0.8P	M8x1.25P	M12x1.75P	M16x2.0P	M20x2.5P	-
D7	80	118	148	186	239	-
L1	60	90	115	142	182	-
L2	37	48	63	91.5	100.5	-
L3	7	10	10	10	16	-
L4	1.5	1.5	3	6	2.5	-
L5	25	32	40	60	70	-
L6	2	3	5	5	6	-
L7	6	8	11	16	18	-
L8	151.8	200.7	272.5	345.5	424.5	-
L9	4	4.5	6	6	8	-
L10	16.5	20.5	30	38	48	-
L11	13.5	21.5	22	32	44.7	-
C1 ²	46	70	90	115	145	-
C2 ²	M4x0.7P	M5x0.8P	M6x1.0P	M8x1.25P	M8x1.25P	-
C3 ²	≤8	≤14	≤19/≤24	≤24/≤32	≤35	-
C4 ²	29	34	44	53	76	-
C5 ² _{F6}	30	50	70	95	110	-
C6 ²	6	5	5	6	9	-
C7 ²	42.6	60	90	115	140	-
C8 ²	25	33	35	48	65	-
C9 ²	79.5	122.8	147.5	188	207	-
B	5	6	10	12	16	-
H	18	24.5	35	43	59	-

★ C1~C9 are motor specific dimensions(metric std shown). Size may vary according to the motor flange chosen.

★ Specification subject to change without notice.

PGRH Specifications Table

Specifications		Stage	Ratio	PGRH-42	PGRH-60	PGRH-90	PGRH-115	PGRH-142	PGRH-180	PGRH-220
Nominal Output Torque T_{2N}	N • m	1	3	19	53	145	290	520	950	1100
			4	20	55	150	300	550	1000	1700
			5	17	54	140	290	530	1050	2000
			6	15	46	135	280	490	1000	1850
			7	14	44	125	270	450	960	1750
			8	12	41	110	240	390	900	1700
			9	11	37	95	220	360	800	1500
			10	11	37	95	220	360	800	1450
		14	14	44	125	270	450	960	1750	
		20	11	37	95	220	360	800	1450	
		Stage	Ratio	PGRH-42	PGRH-60 (T)	PGRH-90(T)	PGRH-115(T)	PGRH-142(T)	PGRH-180T	PGRH-220T
		2	15	19	53	145	290	520	950	2000
			20	20	55	150	300	550	1000	2000
			25	17	54	140	290	530	1050	2000
			30	17	54	140	290	530	1050	2000
			35	17	54	140	290	530	1050	2000
			40	17	54	140	290	530	1050	2000
			45	17	54	140	290	530	1050	2000
			50	17	54	140	290	530	1050	2000
			60	15	46	135	280	490	1000	2000
			70	14	44	125	270	450	960	1750
			80	12	41	110	240	390	900	1700
			90	11	37	95	220	360	800	1500
			100	11	37	95	220	360	800	1450
120	15		46	135	280	490	1000	1850		
140	14		44	125	270	450	960	1750		
160	12		41	110	240	390	900	1550		
180	11	37	95	220	360	800	1500			
200	11	37	95	220	360	800	1450			
Emergency Stop Torque T_{2NOT}	N • m		3.0 times of Nominal Output Torque (*Max. Output Torque T_{2B} = 60% of Emergency Stop Torque)							
Nominal Input Speed n_{1N}	rpm	1,2	3-200	5000	5000	4000	4000	3000	3000	2000
Max. Input Speed n_{1max}	rpm	1,2	3-200	10000	10000	8000	8000	6000	6000	4000
Micro Backlash P0	arcmin	1	3-20	-	-	≤ 3	≤ 2	≤ 2	≤ 2	≤ 2
		2	15-200	-	-	≤ 5	≤ 4	≤ 4	≤ 4	≤ 4
Precision Backlash P1	arcmin	1	3-20	≤ 5	≤ 5	≤ 5	≤ 4	≤ 4	≤ 4	≤ 4
		2	15-200	≤ 7	≤ 7	≤ 7	≤ 7	≤ 7	≤ 7	≤ 7
Standard Backlash P2	arcmin	1	3-20	≤ 7	≤ 7	≤ 7	≤ 6	≤ 6	≤ 6	≤ 6
		2	15-200	≤ 9	≤ 9	≤ 9	≤ 9	≤ 9	≤ 9	≤ 9
Torsional Rigidity	N • m / arcmin	1,2	3-100	2.5	6	12	23	45	75	130
Max. Radial Load F_{2RB}^1	N	1,2	3-100	760	1570	2780	5340	8400	13000	31810
Max. Axial Load F_{2aB}^1	N	1,2	3-100	410	750	1870	3310	4670	6460	18530
Operating Temp.	°C		3-100	-10 °C ~ +90 °C						
Service Life	hr		3-100	20,000 (10,000/ Continuous operation)						
Efficiency	%	1	3-10	≥ 95%						
		2	12-100	≥ 92%						
Weight	kg	1	3-10	1.0	2.6	6.8	13.5	25.1	42	75
		2	12-100	1.4	3.3/2.9	8.9/7.2	14.8	26.7	46	88
Mounting Position	-	1,2	3-100	Any direction						
Noise Level ²	dBA/1m	1,2	3-100	62	64	66	68	70	72	74
Protection Class	-	1,2	3-100	IP65						
Lubrication	-	1,2	3-100	Synthetic Lubricant						
Inertia(J1)										
Stage	Ratio	unit	PGRH-42	PGRH-60	PGRH-90	PGRH-115	PGRH-142	PGRH-180	PGRH-220	
1	3/4/5/7/9	Kg • cm ²	0.06	0.40	2.28	6.87	24.2	69.8	138.2	
	6/8/10/14/20		0.05	0.30	1.45	4.76	14.5	50.3	103.6	
Stage	Ratio		PGRH-42	PGRH-60(T)	PGRH-90(T)	PGRH-115(T)	PGRH-142(T)	PGRH-180T	PGRH-220T	
2	15/20/25/35/45		0.06	0.40(0.08)	2.28(0.72)	3.02	7.83	27.7	80.3	
	others	0.05	0.30(0.06)	1.45(0.38)	1.64	5.00	15.9	55.3		

* 1. Applied to the output shaft center @100rpm.

* 2. Measured at 3000rpm with no load

※ The above figures/specifications are subject to change without prior notice.

Products due to human error, natural disasters or other factors lead to poor or damaged, will not be covered under warranty.