

BRUSHLESS DC MOTOR UNIT - L Series

DIMENSIONS

K9LH100N2 + K9H□BTH

(Weight : 3.4Kg)

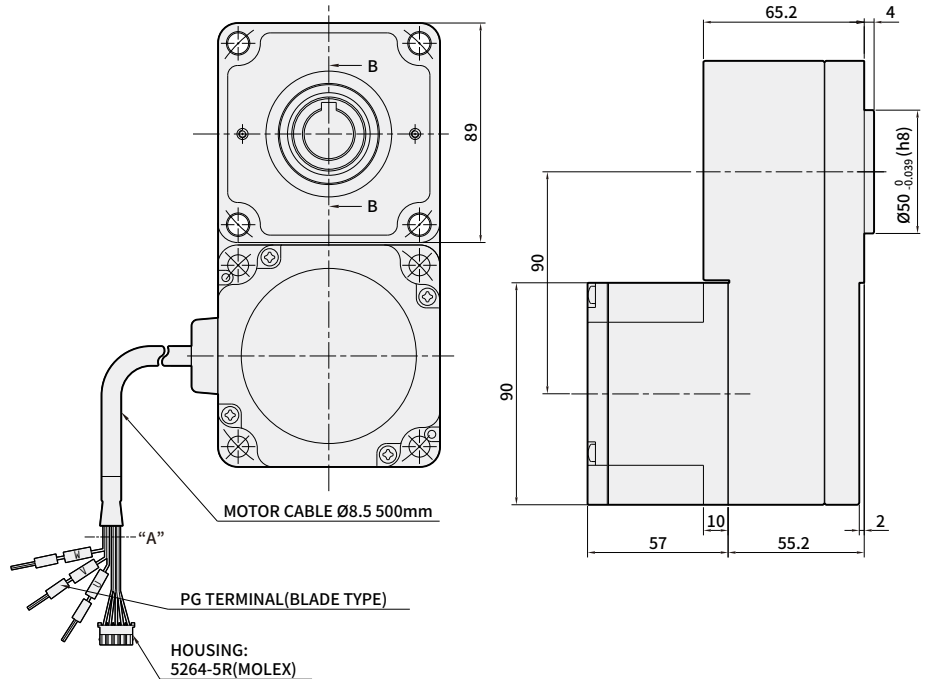

* KEY · KEY GROOVE (ACCESSORY)

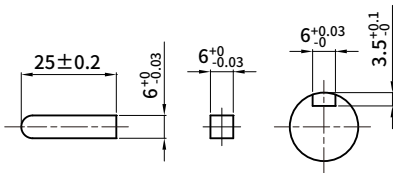

* CONNECTOR HOUSING & PGTERMINAL (VIEW A)

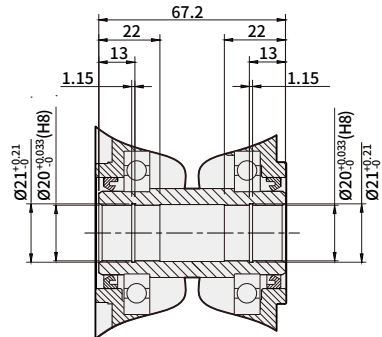
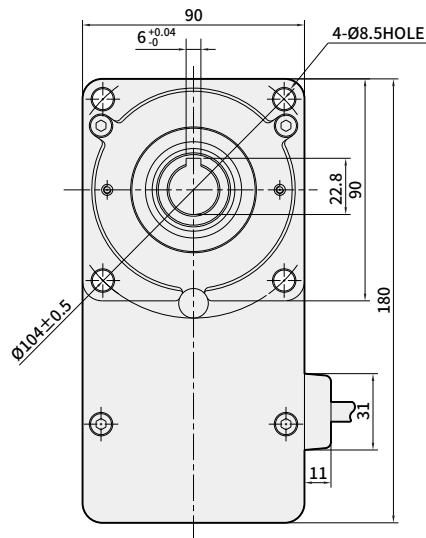
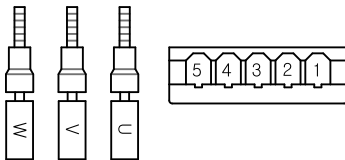

SECTION B-B

* PIN MAP

MOTOR PRODUCT NAME	GEARHEAD PRODUCT NAME	DECELERATION RATIO	FIXING BOLT
K9LH100N2	K9H□BTH	5~200	M8 P1.25×90

PIN No.	COLOR	SIGNAL
1	BROWN	Hu
2	WHITE	Hv
3	ORANGE	Hw
4	GREEN	Ground
5	YELLOW	Vcc
-	BLUE	U
-	PURPLE	V
-	GRAY	W

* In □ of name, it represents a deceleration ratio.

* Mounting bolt sets are included in flat type gearbox.
M8×90L (flat washer, spring washer, hexagonal nut 4pcs each)

→ Specification

Product name	GEAR TYPE	K6LH30N2	K8LH50N2	K9LH100N2
	D-CUT TYPE	K6LS30N2	K8LS50N2	K9LS100N2
Rating output (continuous)	W	30	50	100
Power input	Rating voltage	V DC24		
	Rating voltage allowance	±10%		
	Rating input current	A 2.1	A 3.1	A 6.0
	Rating output current	A 3.7	A 5.4	A 9.8
Rating torque	N·m(kgf·cm)	0.12	0.2	0.4
Starting torque	N·m(kgf·cm)	0.15	0.24	0.5
Rating rotation speed	r/min	2500		
Speed control range	r/min	100~3000		
Allowed inertia load moment of round shaft type	J×10 ⁻⁴ kg·m ²	1.8	3.3	5.6
Rotor inertia moment	J×10 ⁻⁴ kg·m ²	0.086	0.234	0.611
Speed change rate	Load	Less than or equal to ±1% : condition 0-rated torque, rated rotation speed, rated voltage, room temperature		
	Voltage	Less than or equal to ±1% : condition rating voltage ±10%, rating rotation speed, no load, room temperature		
	Temperature	Less than or equal to ±1% : condition surrounding temperature 0~+40°C, rating rotation speed, no load, rating voltage		

- * The usage duration for starting torque is within 5 seconds at less than 2000 r/min
- * Each specification value is the characteristic of motor by itself

→ Common specifications

Product name	Specification
Rotation speed setting method	<ul style="list-style-type: none"> ● Set up by external potentiometer ● Set up by external DC 0~5V
Acceleration time deceleration time	0.5~10 seconds : set at 2000 r/min when there is no load (it may change depending on the size of the load) Acceleration time and deceleration control equipment to control at the same time
Input signal	Internal full-up input method, external input voltage read as greater than 2v high(off) same at all input ports
Output signal	Open collector output, common for speed out/alarm out, if input voltage from out side is applied to connector #2 pin, then it comes out through the applied power. Everything else is internal 5V output UI(CTRL)
Protection function	If the following protection mode comes on, control unit alarm signal is shown. Motor stops automatically. <ul style="list-style-type: none"> ● Overload protection mode : If torque that is greater than the rating is applied to the motor for more than 5 seconds ● Overvoltage protection : If voltage applied to the control unit goes over the upper bound of the rating allowance ● Open phase protection : If cable sensor line gets disconnected during motor operation ● Undervoltage protection : If voltage applied to the control unit is less than the lower bound of the rating voltage allowance ● Over speed protection : If motor rotation speed is faster than 2500 r/min
Motor insulation class	E TYPE(120°C)
Maximum extension distance	MOTOR - CONTROL UNIT 2m
Rated time	Continuous

- * Like weight carried being downwards, L SERIES cannot control motor speed through weight. Motor gets stopped automatically through overvoltage protection of load is being carried downwards or it is heavier than allowed load inertia.

→ Normal specifications

Items		Motor	Control unit
Insulation Resistance		After being operated continuously at room temperature and humidity, the value measured between coil and vase by DC 500V MEGA is greater than or equal to 100MΩ	After being operated continuously at room temperature and humidity, the value measured between heatproof plate and power input is greater than or equal to 100MΩ
Dielectric Strength		After being operated continuously at room temperature and humidity, there shouldn't be any problem between coil and case even when AC 0.5kV is applied for 1 minute	No problem when 50Hz, AC 0.5kV is applied for one minute No problem when AC 0.5kV is applied for one minute
Used environment	Used Ambient temperature	0℃~+50℃ (should not freeze)	
	Used Ambient Humidity	less than or equal to 85% (not from dews)	
	Vibration	Altitude less than 1000m	
	Ambient environment	Cannot be used under special circumstances such as with corrosive gas, dust, radioactive material, magnetic and vacuum	
	Vibration	Should not apply constant vibration or huge impact according to the JIS C 60068-2-6 sine wave vibration test method Frequency range : 10~55Hz, peak amplitude : 0.15mm, sweet direction : 3 direction(X,Y,Z), number of sweeps : 20 times	
Conservation environment	Ambient temperature	-25 ~ +70℃ (should not freeze)	
	Ambient Humidity	less than or equal to 85% (not form dews)	
	Altitude	Altitude less than 3000m	
Insulation class		UL, CSA STANDARD A TYPE(105℃), EN STANDARD E TYPE(120℃)	
Protection class		IP65	IPO0

- * Preservation environment is a short-term value, which includes transportation.
- * Do not measure insulation resistance and pressure resistance while motor and driver are connected

→ Allowed torque of combination type

Unit = upper part : N·m / lower part : kgf·cm

Items	Deceleration ratio	Speed control range [r/min]	5	10	15	20	30	50	100	200
			20~500	10~250	6.7~167	5~125	3.3~83	2~50	1~25	0.5~12.5
			600	300	200	150	100	60	30	15
K6LH30N2 + K6H□B	100~2500r/min	100~2500r/min	0.54 5.4	1.1 11	1.6 16	2.2 22	3.1 31	5.2 52	6 60	6 60
		3000r/min	0.27 2.7	0.54 5.4	0.81 8.1	1.1 11	1.5 15	2.6 26	5.2 52	6 60
K8LH50N2 + K8H□B	100~2500r/min	100~2500r/min	0.9 9	1.8 18	2.7 27	3.6 36	5.2 52	8.6 86	16 160	16 160
		3000r/min	0.45 4.5	0.9 9	1.4 14	1.8 18	2.6 26	4.3 43	8.6 86	16 160
K9LH100N2 + K9H□B	100~2500r/min	100~2500r/min	1.8 18	3.6 36	5.4 54	7.2 72	10.3 103	17.2 172	30 300	30 300
		3000r/min	0.9 9	1.8 18	2.7 27	3.6 36	5.2 52	8.6 86	17.2 172	30 300
K6LH30N2 + K6H□BTH	100~2500r/min	100~2500r/min	0.48 4.8	1 10	1.5 15	2 20	3.1 31	5.1 51	10.2 102	17 170
		3000r/min	0.24 2.4	0.51 5.1	0.77 7.7	1 10	1.5 15	2.6 26	5.1 51	10.2 102
K8LH50N2 + K8H□BTH	100~2500r/min	100~2500r/min	0.85 8.5	1.7 17	2.6 26	3.4 34	5.1 51	8.5 85	17 170	34 340
		3000r/min	0.43 4.3	0.85 8.5	1.3 13	1.7 17	2.6 26	4.3 43	8.5 85	17 170
K9LH100N2 + K9H□BTH	100~2500r/min	100~2500r/min	1.7 17	3.4 34	5.1 51	6.8 68	10.2 102	17 170	34 340	68 680
		3000r/min	0.85 8.5	1.7 17	2.6 26	3.4 34	5.1 51	8.5 85	17 170	34 340

- * Rotation direction shows the same color as the motor. In other cases, it's the opposite.
- * Flat Gearbox viewed from front side is opposite rotation direction with motor.
Flat Gearbox viewed from back side is same rotation direction with motor.

→ Allowed overhang load and allowed thrust

Product name		Deceleration ratio	Allowed overhand load				Allowed thrust load	
			From the end of output part : 10mm		From the end of output part : 20mm		N	kgf
			N	kgf	N	kgf		
GEARED MOTOR	K6LH30N2 + K6H□B	5	100	10	150	15	40	4
		10~20	150	15	200	20		
		30~200	200	20	300	30		
	K8LH50N2 + K8H□B	5	200	20	250	25	100	10
		10~20	300	30	350	35		
		30~200	450	45	550	55		
	K9LH100N2 + K9H□B	5	300	30	400	40	150	15
		10~20	400	40	500	50		
		30~200	500	50	650	65		
	K6LH30N2 + K6H□BTH	5~10	450	45	370	37	200	20
		15~200	500	50	400	40		
	K8LH50N2 + K8H□BTH	5~10	800	80	660	66	400	40
		15~200	1200	120	1000	100		
	K9LH100N2 + K9H□BTH	5~10	900	90	770	77	500	50
		15~20	1300	130	1110	111		
30~200		1500	150	1280	128			
MOTOR	K6LS30N2		70	7	100	10	·Be careful not to weigh thrust. If it's inevitable, keep it under 50% of the motor weight.	
	K8LS50N2		120	12	140	14		
	K9LS100N2		160	16	170	17		

* In □ of name, it represents a deceleration ratio.

* Permissible overhang load can be withdrawn by calculation.

→ Rotation speed- torque characteristic

K6LS30N2 / K6LH30N2

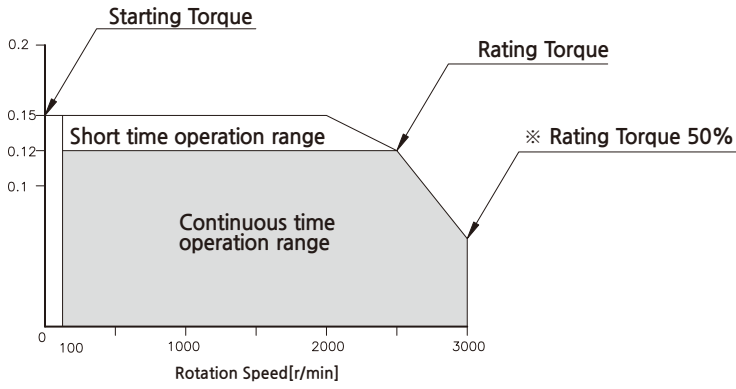

※ DC24V is the value without cable extension.

K8LS50N2 / K8LH50N2

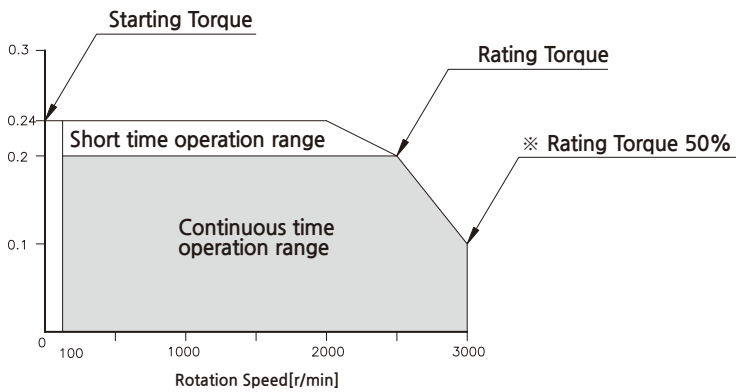

※ DC24V is the value without cable extension.

K9LS100N2 / K9LH100N2

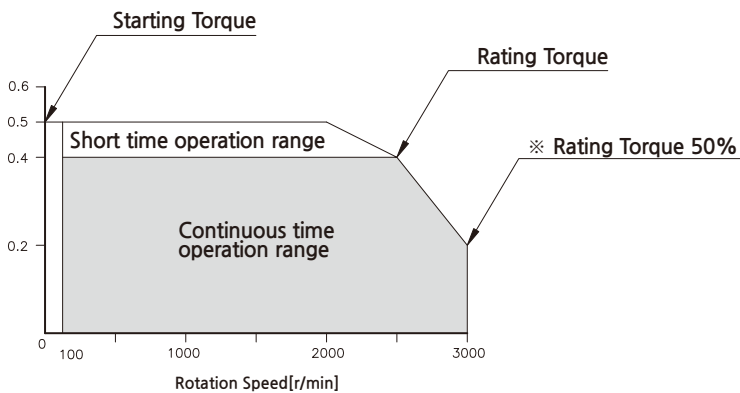

※ DC24V is the value without cable extension.